

APEC EUROSTAT IEA IEF OLADE OPEC UNSD  
JOINT ORGANISATIONS DATA INITIATIVE

# JODI OIL MANUAL

2<sup>ND</sup> EDITION

[www.jodidata.org](http://www.jodidata.org)





## ASIA PACIFIC ECONOMIC COOPERATION (APEC)

APEC is an intergovernmental grouping operating on the basis of non-binding commitments, open dialogue and equal respect for the views of all participants. It was established in 1989 to further enhance economic growth and prosperity for the region and to strengthen the Asia-Pacific community.

APEC's 21 Member Economies are Australia; Brunei Darussalam; Canada; Chile; People's Republic of China; Hong Kong, China; Indonesia; Japan; Republic of Korea; Malaysia; Mexico; New Zealand; Papua New Guinea; Peru; The Republic of the Philippines; The Russian Federation; Singapore; Chinese Taipei; Thailand; The United States of America; and Viet Nam.

Since its inception, APEC has worked to reduce tariffs and other trade barriers across the Asia-Pacific region, creating efficient domestic economies and dramatically increasing exports. Key to achieving APEC's vision are what are referred to as the 'Bogor Goals' of free and open trade and investment in the Asia-Pacific by 2010 for industrialised economies and 2020 for developing economies. These goals were adopted by Leaders at their 1994 meeting in Bogor, Indonesia. APEC's energy issues are the responsibilities of the Energy Working Group (EWG), one of its 11 working groups. The development and maintenance of the APEC Energy Database is assigned to EWG's Expert Group on Energy Data and Analysis (EGEDA) who has appointed the Energy Data and Modelling Centre (EDMC) of the Institute of Energy Economics, Japan (IEEJ) as the Coordinating Agency. One of the objectives of EGEDA is to collect monthly oil data of the APEC economies in support of the Joint Organisations Data Initiative.

**Asia Pacific Economic Cooperation (APEC)** – [www.ieej.or.jp/egeda](http://www.ieej.or.jp/egeda)  
INUI. Bldg Kachidoki, 13-1, Kachidoki 1-Chome, Chuo-Ku, Tokyo 104-0054, Japan

## EUROSTAT

Eurostat is the Statistical Office of the European Communities. Its task is to provide the European Union with statistics, at a European level, that allow comparisons to be made between countries and regions. Eurostat consolidates and harmonises the data collected by the Member States. To ensure that the vast quantity of accessible data is made widely available and to help each user make proper use of the information, Eurostat has set up a publications and services programme. This programme makes a clear distinction between general and specialist users and particular collections have been developed for these different groups. The collections' Press releases, Statistics in focus, Panorama of the European Union, Pocketbooks and Catalogues are aimed at general users. They give immediate key information through analyses, tables, graphs and maps. The collections' methods and nomenclatures and detailed tables suit the needs of the specialist who is prepared to spend more time analysing and using very detailed information and tables. As part of the new programme, Eurostat has developed its website. It includes a broad range of online information on Eurostat products and services, newsletters, catalogues, online publications and indicators on the euro zone.

**Statistical Office of the European Communities (EUROSTAT)** – [epp.eurostat.ec.europa.eu](http://epp.eurostat.ec.europa.eu)  
BECH Building, 5, rue Alphonse Weicker, L-2721 Luxembourg

## INTERNATIONAL ENERGY AGENCY

The International Energy Agency (IEA) works to ensure reliable, affordable and clean energy for its 28 member countries and beyond. Founded in 1974, the IEA's initial role was to help countries co-ordinate a collective response to major disruptions in oil supply through the release of emergency oil stocks to the markets. While this continues to be a key aspect of its work, the IEA has evolved and expanded. It is at the heart of global dialogue on energy, and now works closely with non-member countries to find solutions to shared energy and environmental concerns. It is one of the world's most authoritative sources for energy statistics, and produces annual studies on oil, natural gas, coal, electricity and renewables. The IEA also provides authoritative, unbiased research and analysis which focuses on:

- **Energy security:** Promoting diversity, efficiency and flexibility within all energy sectors.
- **Economic development:** Ensuring the stable supply of energy to IEA member countries and promoting free markets to foster economic growth and eliminate energy poverty.
- **Environmental awareness:** Enhancing international knowledge of options for tackling climate change.

**International Energy Agency (IEA)** – [www.iea.org](http://www.iea.org)  
9, rue de la Federation, 75739 Paris Cedex 15, France

### **THE LATIN-AMERICAN ENERGY ORGANISATION (OLADE)**

The Latin-American Energy Organisation (OLADE) is an international public entity of cooperation, coordination and advising. Its fundamental purpose is integration, protection, conservation, defence and rational use of energy resources of the Region.

The fundamental objectives of the organisation are as follows:

- Political and technical tool for prompting better regional energy integration.
- Manage official statistics, products and services and regional energy planning.
- Encourage training inside the Energy Ministries of the Member Countries.
- Promote regional energy cooperation among countries.

Member Countries: Argentina, Barbados, Belize, Bolivia, Brazil, Colombia, Costa Rica, Cuba, Chile, Ecuador, El Salvador, Grenada, Guatemala, Guyana, Haiti, Honduras, Jamaica, Mexico, Nicaragua, Panama, Paraguay, Peru, Dominican Republic, Suriname, Trinidad & Tobago, Uruguay and Venezuela.

**Latin-American Energy Organisation (OLADE)** - [www.olade.org](http://www.olade.org)

Av. Mariscal Sucre No. N58-63 & Fernandez Salvador, OLADE Bldg, P.O. Box 17-11-6413 Quito, Ecuador

### **THE ORGANIZATION OF PETROLEUM EXPORTING COUNTRIES (OPEC)**

The Organization of the Petroleum Exporting Countries (OPEC) is a permanent intergovernmental organization of oil-exporting developing nations that coordinates and unifies the petroleum policies of its Member Countries. OPEC seeks to ensure the stabilization of oil prices in international oil markets, with a view to eliminating harmful and unnecessary fluctuations, due regard being given at all times to the interests of oil-producing nations and to the necessity of securing a steady income for them. Equally important is OPEC's role in overseeing an efficient, economic and regular supply of petroleum to consuming nations, and a fair return on capital to those investing in the petroleum industry.

OPEC was formed on September 14, 1960, at a meeting in Baghdad, the Iraqi capital, attended by five countries that became the founding members. It was registered with the United Nations Secretariat on November 6, 1962, following UN Resolution No. 6363. Also in attendance at the Baghdad meeting were - Islamic Republic of Iran, Iraq, Kuwait, Saudi Arabia and Venezuela. They signed the original agreement establishing OPEC. Currently, the organization has twelve members, namely: Algeria, Angola, Ecuador, IR Iran, Iraq, Kuwait, Libya, Nigeria, Qatar, Saudi Arabia, United Arab Emirates and Venezuela.

**Organization of Petroleum Exporting Countries (OPEC)** - [www.opec.org](http://www.opec.org)

Helferstorferstrasse 17, A-1010 Vienna, Austria

### **UNITED NATIONS STATISTICS DIVISION (UNSD)**

The United Nations Statistics Division (UNSD) collects, processes and disseminates statistical information covering a broad range of statistical domains, such as demography, energy, environment, industry, international trade, national accounts, social and housing statistics.

In addition to compiling and disseminating global statistical information, the Division's key activities include the development of standards and norms for statistical activities, assistance to countries in the implementation of these standards and general support to strengthen countries' national statistical systems.

UNSD serves as the central mechanism within the Secretariat of the United Nations to satisfy the statistical needs and coordinating activities of the global statistical system. UNSD also provides support to the functioning of the UN Statistical Commission, the apex entity of the global statistical system, which brings together the Chief Statisticians from United Nations member states from around the world.

In the field of energy statistics, UNSD started its regular data collection in 1950. It now compiles and disseminates energy statistics for more than 190 countries/territories, published in two annual publications, the Energy Statistics Yearbook and the Energy Balances and Electricity Profiles, as well as an electronic database, which can also be accessed through the UN data portal.

UNSD is cooperating with many international, regional and supranational agencies in the work on statistical standards, data collection and statistical capacity building, including in the field of energy statistics.

**United Nations Statistics Division (UNSD)** - [unstats.un.org](http://unstats.un.org)

2 UN Plaza, DC2-1414, New-York, NY 10017, USA

## **INTERNATIONAL ENERGY FORUM (IEF)**

The IEF aims to foster greater mutual understanding and awareness of common energy interests among its 89 member countries.

Covering all six continents and accounting for around 90% of global supply and demand for oil and gas, the IEF is unique in that it comprises not only consuming and producing countries of the IEA and OPEC, but also Transit States and major players outside of their memberships, including Argentina, Brazil, China, India, Mexico, Oman, Russia and South Africa. Sitting alongside other important developed and developing economies on the 31 strong IEF Executive Board, these key nations are active supporters of the global energy dialogue through the IEF.

Recognising their interdependence in the field of energy, the member countries of the IEF co-operate under the neutral framework of the Forum to foster greater mutual understanding and awareness of common energy interests in order to ensure global energy security. The Forum's biennial Ministerial Meetings are the world's largest gathering of Energy Ministers. The magnitude and diversity of this engagement is a testament to the position of the IEF as a neutral facilitator and honest broker of solutions in the common interest. The IEF and the global energy dialogue are promoted by a permanent Secretariat of international staff based in the Diplomatic Quarter of Riyadh, Saudi Arabia.

**International Energy Forum (IEF)** – [www.ief.org](http://www.ief.org)  
Diplomatic Quarter, P.O. Box 94736, Riyadh 11614, Saudi Arabia

Comments can also be sent to the following e-mail address: [\*\*jodi.info@ief.org\*\*](mailto:jodi.info@ief.org)



# Table of contents

---

<b>Lists of Figures and Tables .....</b>	<b>8</b>
<b>Foreword .....</b>	<b>9</b>
<b>Preface .....</b>	<b>11</b>
<b>Acknowledgements .....</b>	<b>13</b>
<b>1. Introduction .....</b>	<b>15</b>
<b>2. The JODI Oil Questionnaire .....</b>	<b>17</b>
2.1 The questionnaire.....	17
2.2 Instructions for completion.....	17
2.3 Short definitions.....	18
<b>3. Product Definitions.....</b>	<b>21</b>
3.1 Crude oil .....	21
3.2 NGL .....	22
3.3 Other .....	23
3.4 Total .....	25
3.5 LPG .....	25
3.6 Naphtha .....	27
3.7 Motor and aviation gasoline.....	28
3.8 Kerosenes .....	30
3.9 Gas/Diesel oil.....	31
3.10 Fuel oil .....	33
3.11 Other oil products.....	34
3.12 Total oil products .....	37
<b>4. Flow Definitions .....</b>	<b>39</b>
4.1 Production (Crude Oil/NGL/Other).....	39
4.2 From other sources .....	41
4.3 Imports and Exports.....	41
4.4 Products transferred / Backflows.....	43
4.5 Direct use.....	43
4.6 Stock change.....	44
4.7 Statistical difference .....	45
4.8 Refinery intake.....	45
4.9 Closing stocks .....	46
4.9.1 What are primary, secondary and tertiary stocks?.....	46
4.9.2 What data should be collected?.....	47
4.9.3 Location of stocks.....	48
4.9.4 Timing / Cut off date.....	48
4.9.5 Availability of stocks data .....	48
4.10 Refinery output.....	49
4.11 Receipts .....	51
4.12 Products transferred .....	52
4.13 Interproduct transfers .....	52
4.14 Demand .....	52

---

---

<b>5. Verification of Data Quality</b> .....	<b>55</b>
5.1 Data quality assessment.....	55
5.2 Focus on data accuracy.....	55
5.2.1 Balance check.....	56
5.2.1.1 Fuel balance: sum of products versus total oil products .....	57
5.2.1.2 Stocks check .....	58
5.2.2 Time series check .....	59
5.2.3 Refinery intake/output check .....	60
5.2.4 Visual checks .....	62
5.3. Monthly versus annual data .....	62
5.3.1 Monthly data .....	62
5.3.1.1 Data collection and coverage .....	62
5.3.1.2 Estimates or full coverage data.....	63
5.3.1.3 Missing monthly data .....	63
5.3.2 Annual data.....	63
5.3.2.1 Annual data is a simply sum of the 12 consecutive months of the year .....	63
5.3.2.2 Monthly data is to be reconsolidated in order to derive annual data from the monthly data.....	63
5.4. Common reporting errors.....	63
<b>6. Estimations and Revisions of data</b> .....	<b>67</b>
6.1 Estimations.....	67
6.1.1 Data are not collected.....	67
6.1.2 Data are exceptionally not available .....	70
6.2 Revisions .....	72
<b>7. Examples of Practices</b>	
A few Examples of JODI Oil Data Collection and Methodology in Participating Countries.....	<b>73</b>
7.1 Example of practice: Argentina.....	73
7.2 Example of practice: Croatia .....	74
7.3 Example of practice: Egypt.....	75
7.4 Example of practice: France .....	76
7.5 Example of practice: Norway .....	77
7.6 Example of practice: Philippines .....	79
7.7 Example of practice: Saudi Arabia .....	82
<b>8. The JODI Oil World Database</b> .....	<b>83</b>
8.1 Background.....	83
8.2 Building the JODI Oil World Database.....	83
8.3 The JODI Oil World Database .....	84
8.3.1 How to access?.....	84
8.3.2 What is included?.....	84
8.3.3 Some features .....	85
8.3.4 Colour coding.....	85
<b>Annex 1: The Refinery process</b> .....	<b>87</b>
<b>Annex 2: Units and conversion factors</b> .....	<b>89</b>
<b>List of abbreviations</b> .....	<b>93</b>

---



# Figures and Tables

---

## List of figures

Figure 3.1	Production of LPG.....	26
Figure 4.1	Wellhead versus marketable production.....	39
Figure 4.2	Main refinery flows.....	50
Figure 4.3	Demand flows.....	53
Figure 5.1	Refinery intake comparison in tons.....	61
Figure 5.2	Refinery intake comparisons in kbbl.....	61
Figure 5.3	Refinery intake volumes.....	62
Figure 7.1	Downstream oil sector.....	79
Figure 8.1	Dataflow to the IEF.....	84
Figure 8.2	A view from the database.....	85
Figure A1.1	Operation of a typical refinery.....	87
Figure A2.1	Oil industry flow.....	94

## List of tables

Table 4.1	Example 1 of reporting Direct use of NGL.....	51
Table 5.1	Example 1 of internal balance check.....	57
Table 5.2	Example 1 of fuel balance check.....	57
Table 5.3	Example 2 of fuel balance check.....	58
Table 5.4	Example of checking consistency of stocks data.....	58
Table 5.5	Comparing growth rate for the latest month to the historical trend.....	59
Table 6.1	Annual balance for country Z.....	68
Table 6.2	Monthly JODI Oil data for country Z.....	69
Table 6.3	Refinery output of gas/diesel oil of country Z.....	70
Table 6.4	How to estimate missing data – example 1.....	70
Table 6.5	How to estimate missing data – example 2.....	71
Table 6.6	How to estimate missing data – example 3.....	71
Table A2.1	Most common multiple and sub-multiple prefixes.....	89
Table A2.2	Conversion equivalents between units of volume.....	90
Table A2.3	Conversion equivalents between units of mass.....	90
Table A2.4	Conversion equivalents between units of energy.....	90
Table A2.5	Typical densities, conversion factors and calorific values for crude oil and petroleum products.....	92
Table A2.6	Example of converting volume to mass.....	92

# Foreword

---

The Joint Organisations Data Initiative is a concrete outcome of the producer-consumer energy dialogue. The importance of exchanging data as a means to enhance transparency of global energy commodity markets is recognised by IEF Energy Ministers as beneficial to energy security and in the interest of producers and consumers alike. The initiative relies on the combined efforts of producing and consuming countries and the seven JODI partner organisations to build the timely, comprehensive, and sustainable energy data provision architecture which is a prerequisite for stable energy commodity markets. By helping to mitigate some of the uncertainties that may be detrimental to market functionality, JODI aims to moderate undue price volatility, thereby increasing investor confidence and contributing to greater stability in energy markets worldwide.

JODI has been successful in delivering improved energy market transparency. JODI's data collection architecture has demonstrated its ability to provide more timely oil market information, but timeliness alone is not enough. Timeliness, accuracy and completeness must all be given equal weighting if the data are to yield their full potential, but for some countries there is still ample room for improvement in the latter two measures. As the initiative moves to an extended format, with three times as many data points, even historically strong JODI performers will have to work hard to rise to the challenge of maintaining their performance. Support from and co-operation among the JODI partners and an increased focus on capacity building will be key determinants of success for the next stage of JODI's development.

Energy Ministers as well as world leaders have consistently expressed their strong support for JODI and continue to call for improved energy market data transparency. Such political support is essential and JODI organisations have been diligent in their efforts to provide the market with more comprehensive data.

This Manual was prepared jointly by the IEF and its JODI Oil partners (APEC, Eurostat, IEA, OLADE, OPEC and UNSD). Our objective is to help data collectors and users understand the methodology and definitions used in the JODI Oil questionnaire. Along with training sessions on JODI conducted by IEF and partner organisations, this Manual will help data collectors to conduct basic verification of data, avoid common reporting errors and share examples of best practices.

This second edition of the JODI Oil Manual is another important milestone on the road to more transparent energy markets through improved data.

**Aldo Flores Quiroga**  
Secretary General  
International Energy Forum



# Preface

---

Since the end of the 1990s the world has faced high oil price volatility. The lack of transparent and reliable oil statistics was identified as a contributory factor to the volatility. This is in addition to externalities including political tension and economic shocks. Efforts to improve the availability and reliability of oil data began among producers and consumers, who recognised the need for more data transparency in the oil market. Ministers at the 7<sup>th</sup> International Energy Forum in Riyadh in 2000 made clear their support for better data and urged a global response to the challenge.

## **Evolution from the 7<sup>th</sup> to 10<sup>th</sup> International Energy Forum: From an exercise to an initiative and a database.**

Six international organisations – APEC, Eurostat, IEA, OLADE, OPEC and UNSD – took up the challenge, combined their efforts, involved their Member Countries and, in April 2001 launched the **Joint Oil Data Exercise (JODE)**. The primary goal was not to build a database, but to raise the awareness of all oil market players to the need for more transparency of oil market data.

The first priority of the six organisations was to assess the oil data situation in their respective member countries in order to better qualify and quantify the perceived lack of transparency. The assessment included the collection of up-to-date monthly oil statistics from each organisation's member countries through a harmonized questionnaire on 42 key oil data points.

Progress was immediate: Within six months, 55 countries were already participating in the exercise. Six months later there were over 70 participating countries, representing 90 per cent of global oil supply and demand. At the 8<sup>th</sup> International Energy Forum in Osaka in 2002, Ministers commended the work, reaffirmed their political support and urged the organisations to redouble their efforts.

Having obtained the political mandate to reinforce their work, the six organisations obtained agreement from their Member Countries to make the Exercise a permanent reporting mechanism; the Exercise was then renamed the **Joint Oil Data Initiative (JODI)**.

As the process gathered momentum, more countries participated and their submissions became more timely, complete, and of higher quality. It became, therefore, desirable to assemble all the information in a compatible form: The **JODI Oil World Database** was born.

Participants in the 5<sup>th</sup> JODI Conference in October 2004 strongly recommended that this joint global database be made freely accessible to all – organisations, countries, industry, analysts and others.

## **From concept to launch and further developments**

Transparency does not happen overnight and despite the significant progress achieved since its inception, the database is still far from perfect. The IEF Secretariat, which took over the co-ordination of JODI in January 2005, and the six partner organisations are fully aware of the limits and limitations of the database at this stage of its development. However, since transparency is central to the initiative, the organisations responded positively to the request expressed at the 5<sup>th</sup> JODI Conference for the database to be made accessible to the public.

In October 2005, the organisations agreed to open the JODI Oil World Database. The database was officially launched on the occasion of the inauguration of the IEF Headquarters building in Riyadh, by King Abdullah of Saudi Arabia on 19 November 2005.

As a result of the 6th International JODI (Oil) conference in Riyadh, JODI partner organisations conducted an extended format data collection trial over two years and concluded that the extension was feasible. Following its endorsement at the 7th International JODI Conference in Quito, the seven JODI organisations implemented the extended JODI questionnaire as a permanent activity. This extended format gives a more detailed and accurate view of the supply - demand picture.

The JODI partners' establishment of a world oil data collection system inspired IEF Ministers to call for an extension of the Initiative to cover natural gas (JODI Gas) and annual data on upstream and downstream capacity and expansion plans. To accommodate progress on these new challenges beyond oil data transparency, the seven JODI partner organisations have now re-branded JODI as the **Joint Organisations Data Initiative**.

### **A continuous process...**

The database is and always will be work in progress. Timeliness, sustainability and completeness can always be improved upon, but the quality of data also constitutes an essential element of a good database.

The organisations therefore jointly decided that several measures could be taken to help national administrations further enhance data quality when completing the JODI Oil questionnaire. As a point of departure, the first edition of JODI Oil manual became available with the necessary guidelines and technical instructions. This second edition will include definitions of newly added products and flows as well as in-depth explanations and additional diagrams of the oil industry's highly complex value chain. To further improve the data submitted to JODI, and to build capacity among its participants, the IEF and the JODI partner organisations have established the regional training workshop programme which offers statisticians and experts from participating countries an opportunity to improve their knowledge of definitions, data quality assessment and oil data issues. The workshops also offer a platform for JODI users to share their experiences and communicate best practices for oil data management.

The ultimate goal of this initiative is full data transparency - a complete and comprehensive database with good quality data, updated on a timely basis and providing an overview of the global oil situation. We hope that the publication of this manual brings us a little closer to achieving this objective.

# Acknowledgements

---

This manual was prepared by the Energy Division of the International Energy Forum (IEF) and its partners in the Joint Organisations Data Initiative (JODI): the Asia Pacific Economic Cooperation (APEC), the Statistical Office of the European Communities (Eurostat), the International Energy Agency (IEA), the Latin American Energy Organisation (OLADE), the Organisation for Petroleum Exporting Countries (OPEC), and the United Nations Statistics Division (UNSD).

The ongoing success of JODI relies on the sustained and active participation and support of all key actors. Therefore special acknowledgement is due to Argentina, Croatia, Egypt, France, Norway, Philippines, and Saudi Arabia, the countries whose case studies appear in the manual. Thanks are also due to the many other participating countries that volunteered material for publication: Algeria, Bulgaria, Costa Rica, Cyprus, Estonia, Latvia, Lithuania, Mexico, Romania, Sweden and Uruguay. The depth of the material submitted has added considerable value to the development of the JODI Oil training programme as well as to the comprehensiveness of the manual.

JODI continues to evolve and this publication is a living document. Feedback is an essential element in the drive for progress and comments on the Initiative are actively encouraged. Please submit questions or observations on the implementation of JODI by email to [jodi.info@ief.org](mailto:jodi.info@ief.org).



# Chapter 1: Introduction

---

The purpose of this manual is to provide data collectors and users with a full explanation of the methodology and definitions used in the JODI Oil (Joint Organisations Data Initiative Oil) questionnaire. Moreover it was deemed useful to supply some background information on how oil is produced, refined, etc.

At the outset of JODI Oil, when the questionnaire was designed, the six international organisations involved in the initiative at that time agreed to limit the number of data points requested in the JODI Oil questionnaire to a minimum. The initial objective of the JODI indeed was not to start a new data collection system, but to determine how many countries could submit monthly data on a regular basis. JODI has evolved considerably since then and is now a permanent feature for the six organisations. (more information is available on the JODI website: [www.jodidata.org](http://www.jodidata.org))

Only 42 key data points were originally requested: seven product categories (crude oil, LPG, gasoline, kerosene, gas/diesel oil, fuel oil and total oil products) and six flows (production, imports, exports, stock changes, closing stocks and demand). The information requested did not constitute a balance; for a complete oil balance to be reported, information on several other flows would be required (e.g. transfers, direct use, etc.).

In order to have a small and easily understandable questionnaire, the definitions were kept to a minimum, and included only the absolute essentials. Moreover, as the six international organisations were already collecting oil statistics for other purposes, each of them had developed definitions appropriate for their data collection. The idea was therefore that at the onset, definitions would be kept simple, and that more extensive definitions (based on harmonised definitions of the six organisations) would be developed as the initiative evolved.

Upon requests from data users following the launch of the JODI Oil World Database in November 2005, JODI partner organisations introduced an extended format with 126 data points. This extended format includes five additional products (NGL, Other [primary products], Naphtha, Kerosene type jet fuel and Other oil products) as well as 7 additional flows (From other sources, Product transferred, Backflows, Direct use, Statistical difference, Receipts, and Interproduct transfers). This extended format gives a more detailed and accurate view of the supply - demand picture. This second edition of the JODI Oil manual is a revised version of its first edition published in 2006 with addition of definitions for these new products and flows.

Most of the definitions used in this manual are aligned with those contained in the International Recommendations for Energy Statistics (IRES) which have been adopted by the United Nations Statistical Commission in February 2011. The definitions have been developed by InterEnerStat through an extensive consultation process with international and regional organisations active in energy statistics and, as part of the preparation of IRES, they have been subject to a worldwide consultation with countries and international/regional organisations.

The definitions used by the organisations may be differently worded, but the differences may not be so large that they result in dramatically different reporting. Nonetheless each national administration must adhere to the definitions of the organisation they belong to when they submit JODI Oil data.

This manual comprises eight chapters and two annexes. This chapter provides for an introduction; the JODI Oil questionnaire is described in Chapter 2 and the product and flow definitions are addressed in Chapters 3 and 4, respectively. Data verification methodology is in Chapter 5 to guide the data providers in their efforts to improve data quality. Chapter 6 provides information on estimation and revision of data. Chapter 7 serves the data providers by giving real examples of data collection practices together with associated problems and solutions in various countries. Chapter 8 provides information on the JODI Oil World Database. A brief overview of the refinery process is given in Annex 1, which can serve as a quick reference for studying and checking the complicated interplay of products and flows in oil refineries. Annex 2 provides explanations about units and conversion factors which may be needed when submitting JODI Oil data.





# Chapter 2: The JODI Oil Questionnaire

The JODI Oil questionnaire format, definitions and instructions on how to complete it are shown below. The questionnaire is to be submitted on a monthly basis.

## 2.1 The questionnaire

### JOINT ORGANISATIONS DATA INITIATIVE

Country \_\_\_\_\_

Month \_\_\_\_\_

Unit: \_\_\_\_\_

	Crude oil	NGL	Other	Total (1)+(2)+(3)
	(1)	(2)	(3)	(4)
+ Production				
+ From other sources				
+ Imports				
- Exports				
+ Products transferred/ Backflows				
- Direct use				
- Stock change				
- Statistical difference	0	0	0	0
= Refinery intake				
Closing stocks				

	Oil products								
	LPG	Naphtha	Motor/ aviation gasoline	Kerosenes	Of which Kerosene type jet fuel	Gas/ diesel oil	Fuel oil	Other oil products	Total oil products (5)+(6)+(7) +(8)+(10) +(11)+(12)
	(5)	(6)	(7)	(8)	(9)	(10)	(11)	(12)	(13)
+ Refinery output									
+ Receipts									
+ Imports									
- Exports									
- Products transferred									
+ Interproduct transfers									
- Stock change									
- Statistical difference	0	0	0	0	0	0	0	0	0
= Demand									
Closing stocks									

## 2.2 Instructions for completion

### Instructions

#### Deadline for submission: 25th of each month

The Excel form includes two worksheets: one for month M-1 and one for month M-2.

1. Please do not change the format of the Excel form
2. Please make sure that you indicate the **correct data month** in the cell for Month:
3. Do not enter decimal numbers, but only include rounded numbers
4. For specific details, please see the worksheet on Definitions in this spreadsheet.

When completed, please save the Excel file and send to: ... (organisation)

If you have other questions or require furthermore information, please contact: .....(organisation)

## 2.3 Short definitions

APEC/EUROSTAT/IEA/OLADE/OPEC/UNSD

### JODI Oil Short Definitions

Time: **M-1** is Last Month, or the month previous to the current month.  
**M-2** is two months previous to the current month.

#### DESCRIPTION OF PRODUCTS

1. **Crude oil** : Including lease condensate – excluding NGL.
2. **NGL** : Liquid or liquefied hydrocarbons recovered from gas separation plants and gas processing facilities.
3. **Other** : Refinery feedstocks + additives/oxygenates + other hydrocarbons.
4. **Total** : Sum of categories (1) to (3) Total = Crude oil + NGL + Other.
5. **LPG** : Comprises propane and butane.
6. **Naphtha** : Comprises naphtha used as feedstocks for producing high octane gasoline and also as feedstock for the chemical/petrochemical industries.
7. **Motor and aviation gasoline** : Comprises motor gasoline and aviation gasoline.
8. **Kerosenes** : Comprises kerosene type jet fuel and other kerosene.
9. *of which: Kerosene type jet fuel* : Aviation fuel used for aviation turbine power units.  
This amount is a subset of the amount reported under Kerosenes.
10. **Gas/diesel oil** : For automotive and other purposes.
11. **Fuel oil** : Heavy residual oil / boiler oil, including bunker oil.
12. **Other oil products** : Refinery gas, ethane, petroleum coke, lubricants, white spirit & SPB, bitumen, paraffin waxes and other oil products.
13. **Total oil products** : Sum of categories (5) to (12) excluding (9). Demand for Total products includes direct use of Crude oil, NGL and Other.

APEC/EUROSTAT/IEA/OLADE/OPEC/UNSD

**JODI Oil Short Definitions**

Time: **M-1** is Last Month, or the month previous to the current month.

**M-2** is two months previous to the current month.

**DESCRIPTION OF FLOW**

<b>Production</b>	: Marketable production, after removal of impurities but including quantities consumed by the producer in the production process.
<b>From other sources</b>	: Inputs of additives, biofuels and other hydrocarbons that are produced from non-oil sources such as: coal, natural gas or renewables.
<b>Imports/Exports</b>	: Goods having physically crossed the international boundaries, excluding transit trade, international marine and aviation bunkers.
<b>Products transferred /Backflows</b>	: Sum of Products transferred and Backflows from the petrochemical industry.
<b>Direct use</b>	: Refers to crude oil, NGL and Other which are used directly, without being processed in oil refineries, for example: crude oil burned for electricity generation.
<b>Stock change</b>	: Closing minus opening level. A positive number indicates a stockbuild during the period. A negative number indicates a stock draw during the period.
<b>Statistical difference</b>	: Differences between observed supply flows and Refinery intake or Demand.
<b>Refinery intake</b>	: Observed refinery throughputs.
<b>Closing stocks</b>	: Represents the primary stock level at the end of the month within national territories; includes stocks held by importers, refiners, stock holding organisations and governments.
<b>Refinery output</b>	: Gross output (including refinery fuel).
<b>Receipts</b>	: Primary product receipts (quantities of oil used directly without processing in a refinery) + recycled products. Receipts for Other oil products include direct use of crude oil and NGL.
<b>Products transferred</b>	: Imported petroleum products which are reclassified as feedstocks for further processing in the refinery, without delivery to final consumers.
<b>Interproduct transfers</b>	: Reclassification of products, because their specification has changed, or because they are blended into another product: a negative indicates a product that will be reclassified, a positive shows a reclassified product. Interproduct transfers for Other oil products includes interproduct transfers of Crude oil and NGL.
<b>Demand</b>	: Deliveries or sales to the inland market (domestic consumption) plus Refinery fuel plus International marine and aviation bunkers. Demand for Other oil products includes direct use of Crude oil, NGL, and Other.



# Chapter 3: Product definitions

---

This chapter on product definitions and the following one on flow definitions are structured as follows: firstly the definition in the JODI Oil questionnaire is shown, as well as some explanatory notes. Then the different definitions used by the six organisations in charge of collecting the JODI Oil data from their member countries participating in the Initiative are listed, followed by a summary of the differences in the definitions.

Although the differences in the definitions among the organisations may not be significant, national administrations are required to follow the definitions of the organisation to which they belong when they submit JODI Oil data. Consequently, due to these differences in the definitions, sub totals shown in the JODI Oil World Database may lead to small misinterpretations.

## 3.1 Crude oil

### Includes lease condensate

Petroleum is a complex mixture of liquid hydrocarbons, chemical compounds containing hydrogen and carbon, occurring naturally in underground reservoirs in sedimentary rock. Petroleum is normally found at considerable depths beneath the earth's surface, where, under pressure it is essentially liquid. At the surface and atmospheric pressure, petroleum comprises both natural gas and crude oil.

The word petroleum comes from the Latin word *petra*, meaning rock, and *oleum*, meaning oil. The word "petroleum" is often interchanged with the word "oil". Broadly defined, it includes both primary (crude oil or unrefined) and secondary (refined) products.

**Crude oil** is the most important oil from which **oil products** are manufactured but several other feedstock oils are also used to make oil products. There is a wide range of petroleum products manufactured from crude oil. Many are for specific purposes, for example, motor gasoline or lubricants; others are for general heat-raising needs, such as gas oil or fuel oil.

The quality of crude oil depends to a great extent on its density and sulphur content. The crude oils are classified as light, medium and heavy according to their density. Crude oils with high sulphur content (at least 2.5% sulphur) are sour, while sweet crudes have often less than 0.5% sulphur content.

### The different definitions used by the six international organisations:

#### APEC, Eurostat and IEA:

**Crude oil** is mineral oil of natural origin comprising a mixture of hydrocarbons and associated impurities, such as sulphur. It exists in the liquid phase under normal surface temperature and pressure and its physical characteristics (density, viscosity, etc.) are highly variable. This category includes field or lease condensate recovered from associated and non-associated gas where it is co-mingled with the commercial crude oil stream.

#### OLADE:

**Crude oil** is a complex mixture of hydrocarbons of different molecular weights, in which there is a generally small fraction of compounds containing sulphur and nitrogen. The composition of the oil is variable and can be divided into three classes, according to the distillation residues, as paraffins, asphalts or a combination of both. Oil is used as a raw material in refineries for processing and obtaining its derivatives. In specific cases it is also used for final consumption in given industrial activities.

### OPEC:

A mixture of hydrocarbons that exist in a liquid phase in natural underground reservoirs and remain liquid at atmospheric pressure after passing through surface separating facilities. For statistical purposes, volumes reported as crude oil include:

- liquids technically defined as crude oil;
- small amounts of hydrocarbons that exist in the gaseous phase in natural underground reservoirs, but which are liquid at atmospheric pressure after being recovered from oil well (casing head) gas in lease separators;
- small amounts of non-hydrocarbons produced with the oil;
- very heavy and extra-heavy crude oil with viscosity less than 10.000, Pa-s (centipoises) at original reservoir conditions.

### UNSD:

Conventional **Crude Oil**: Mineral oil of fossil origin extracted by conventional means from underground reservoirs, and comprises liquid or near- liquid hydrocarbons and associated impurities such as sulphur and metals.

*Remark:* Conventional crude oil exists in the liquid phase under normal surface temperature and pressure, and usually flows to the surface under the pressure of the reservoir. This is termed "conventional" extraction. Crude oil includes condensate from condensate fields, and "field" or "lease" condensate extracted with the crude oil.

The various crude oils may be classified according to their sulphur content ("sweet" or "sour") and API gravity ("heavy" or "light"). There are no rigorous specifications for the classifications but a heavy crude oil may be assumed to have an API gravity of less than 20° and a sweet crude oil may be assumed to have less than 0.5% sulphur content.

One critical issue is whether the volumes of NGL, lease or field condensates and oils extracted from bituminous minerals are included. All organisations exclude NGL from crude oil. If condensates are able to be excluded, it should be noted to the JODI organisation(s) of which the country/economy is a member. Most OPEC member countries exclude condensates.

## 3.2 NGL [Natural Gas Liquids]

### Liquid or liquefied hydrocarbons recovered from gas separation plants and gas processing facilities

Natural gas liquids are a mixture of ethane, propane, butane (normal and iso), (iso) pentane and a few higher alkanes collectively referred to as pentanes plus.

NGL are produced in association with oil or natural gas. They are removed in field facilities or gas separation plants before sale of the gas. All of the components of NGL except ethane are either liquid at the surface or are liquefied for disposal.

The definition given above is the most commonly used. However, there is some use of terms based on the vapour pressure of the components which are liquid at the surface or can be easily liquefied. The three resulting groups are, in order of increasing vapour pressure: condensates, natural gasoline and liquefied petroleum gas. NGL may be distilled with crude oil in refineries, blended with refined oil products or used directly. NGL differs from LNG (liquefied natural gas) which is obtained by liquefying natural gas from which the NGL has been removed.

## The different definitions used by the six international organisations:

### APEC, Eurostat and IEA:

**NGL** are liquid or liquefied hydrocarbons recovered from natural gas in separation facilities or gas processing plants. Natural gas liquids include ethane, propane, butane (normal and iso-), (iso) pentane and pentanes plus (sometimes referred to as natural gasoline or plant condensate).

### OLADE:

**Definition:** **NGL:** Hydrocarbons found in raw natural gas other than methane.

**Description:** Natural gas liquids are hydrocarbons obtained from wet gas or associated gas in fractionating or separation plants. Natural gas liquids include propane, butane, ethane and pentane.

### OPEC:

**Natural gas liquids (NGL):** those reservoir gases liquefied at the surface in lease separators, field facilities or gas processing plants. NGLs consist of field condensates and natural gas plant products such as ethane, pentane, propane, butane and natural gasoline.

### UNSD:

**Natural gas liquids** are a mixture of ethane, propane, butane (normal and iso), (iso) pentane and a few higher alkanes collectively referred to as pentanes plus.

**Remark:** NGL are produced in association with oil or natural gas. They are removed in field facilities or gas separation plants before sale of the gas. All of the components of NGL except ethane are either liquid at the surface or are liquefied for disposal.

The definition given above is the most commonly used. However, there is some use of terms based on the vapour pressure of the components which are liquid at the surface or can be easily liquefied. The three resulting groups are in order of increasing vapour pressure: condensates, natural gasoline and liquefied petroleum gas. NGL may be distilled with crude oil in refineries, blended with refined oil products or used directly. NGL differs from LNG (liquefied natural gas) which is obtained by liquefying natural gas from which the NGL has been removed.

## 3.3 Other

### Refinery feedstocks + additives/oxygenates + other hydrocarbons

**Refinery feedstocks** are oils or gases from crude oil refining or the processing of hydrocarbons in the petrochemical industry which are destined for further processing in the refinery excluding blending. Typical feedstocks include naphthas, middle distillates, pyrolysis gasoline and heavy oils from vacuum distillation and petrochemical plants.

**Additives and oxygenates** are compounds added to or blended with oil products to modify their properties (octane, cetane, cold properties, etc.).

Examples are:

- oxygenates, such as alcohols (methanol, ethanol), ethers [such as MTBE (methyl tertiary butyl ether), ETBE (ethyl tertiary butyl ether), TAME (tertiary amyl methyl ether)];
- esters (e.g. rapeseed or dimethylester, etc.);
- chemical compounds (such as TML, TEL and detergents).

Some additives/oxygenates may be derived from biomass, others may be of fossil hydrocarbon origin.

**Other hydrocarbons** include non-conventional oils and hydrogen.

Although not a hydrocarbon, hydrogen is included unless it is a component of another gas.

Non conventional oils are obtained by non-conventional production techniques, that is oils which are extracted from reservoirs containing extra heavy oils or oil sands which need heating or treatment (for example, emulsification) *in situ* before they can be brought to the surface for refining/processing. They also include the oils extracted from oil sands, extra heavy oils, coals and oil shale which are at, or can be brought to, the surface without treatment and require processing after mining (*ex situ* processing). Non-conventional oils may also be produced from natural gas.



## The different definitions used by the six international organisations:

### APEC, Eurostat and IEA:

A **refinery feedstock** is a processed oil destined for further processing (e.g. straight run fuel oil or vacuum gas oil) excluding blending. With further processing, it will be transformed into one or more components and/or finished products. This definition also covers returns from the petrochemical industry to the refining industry (e.g. pyrolysis gasoline, C<sub>4</sub> fractions, gasoil and fuel oil fractions).

**Additives** are non-hydrocarbon compounds added to or blended with a product to modify fuel properties (octane, cetane, cold properties, etc.):

- oxygenates, such as alcohols (methanol, ethanol), ethers [(such as MTBE (methyl tertiary butyl ether), ETBE (ethyl tertiary butyl ether), TAME (tertiary amyl methyl ether)];
- esters (e.g. rapeseed or dimethylester, etc.);
- chemical compounds (such as TML, TEL and detergents).

Note: Quantities of additives/oxygenates (alcohols, ethers, esters and other chemical compounds) reported in this category should relate to the quantities destined for blending with fuels or for fuel use.

**Biogasoline:** This category includes bioethanol (ethanol produced from biomass and/or the biodegradable fraction of waste), biomethanol (methanol produced from biomass and/or the biodegradable fraction of waste), bioETBE (ethyl-tertio-butyl-ether produced on the basis of bioethanol: the percentage by volume of bioETBE that is calculated as biofuel is 37%) and bioMTBE (methyl-tertio-butyl-ether produced on the basis of biomethanol: the percentage by volume of bioMTBE that is calculated as biofuel is 22%).

**Bio jet kerosene:** This is liquid biofuel derived from biomass and blended with jet kerosene. Bio jet kerosene can be produced by a range of thermal processes (including for example gasification followed by Fischer Tropsch synthesis, pyrolysis followed by hydrogenation, or conversion of sugar to hydrocarbons using microorganisms (e.g. yeast). A wide range of biomass feedstocks, including cellulosic materials and algal biomass could be used in such processes.

**Biodiesels:** This category includes biodiesel (a methyl-ester produced from vegetable or animal oil, of diesel quality), biodimethylether (dimethylether produced from biomass), Fischer Tropsch (Fischer Tropsch produced from biomass), cold pressed biooil (oil produced from oil seed through mechanical processing only) and all other liquid biofuels which are added to or blended with Gas/diesel oil.

**Other hydrocarbons:** this includes synthetic crude oil from tar sands, shale oil, etc., liquids from coal liquefaction, output of liquids from natural gas conversion into gasoline, hydrogen and emulsified oils (e.g. Orimulsion).

### OLADE:

**Additives/oxygenates** includes alcohol which itself covers both ethanol (ethyl alcohol) and methanol (methyl alcohol) used as fuels.

**Ethanol** is a colorless liquid that can be produced by fermentation of plant materials with a high sugar content, such as sugarcane juice or molasses; plant materials with high starch content, such as cassava, corn, etc.; and materials with high cellulose content: firewood, plant wastes. It can be used as anhydrous or hydrated alcohol, alone or mixed with gasoline in internal combustion engines.

**Methanol** is also a colorless liquid that can be produced from several raw materials such as firewood, plant wastes, methane, natural gas, coal, etc. It is used in internal combustion engines.

#### UNSD:

**Refinery feedstocks:** Oils or gases from crude oil refining or the processing of hydrocarbons in the petrochemical industry which are destined for further processing in the refinery excluding blending. Typical feedstocks include naphthas, middle distillates, pyrolysis gasoline and heavy oils from vacuum distillation and petrochemical plants.

**Additives and oxygenates:** Compounds added to or blended with oil products to modify their properties (octane, cetane, cold properties, etc.).

*Remark:* Examples are: (a) oxygenates such as alcohols (methanol, ethanol) and ethers [MTBE (methyl tertiary butyl ether), ETBE (ethyl tertiary butyl ether), TAME (tertiary amyl methyl ether)]; (b) esters (e.g., rapeseed or dimethylester, etc.); and (c) chemical compounds (such as TML, TEL and detergents). Some additives/oxygenates may be derived from biomass while others may be of fossil hydrocarbon origin.

**Other hydrocarbons:** This division includes non-conventional oils and hydrogen. Non-conventional oils refer to oils obtained by non-conventional production techniques, that is oils which are extracted from reservoirs containing extra heavy oils or oil sands which need heating or treatment (e.g., emulsification) *in situ* before they can be brought to the surface for refining/processing. They also include the oils extracted from oil sands, extra heavy oils, coal and oil shale which are at, or can be brought to, the surface without treatment and require processing after mining (*ex situ* processing). Non-conventional oils may also be produced from natural gas.

*Remark:* The oils may be divided into two groups: (i) oils for transformation (e.g., synthetic crudes extracted from extra heavy oils, oil sands, coal and oil shale); and (ii) oils for direct use (e.g., emulsified oils such as orimulsion and GTL liquids). Oil sands are also known as tar sands. Extra heavy oils are also known as bitumen. This is not the oil product of the same name which is made from vacuum distillation residue. Although not a hydrocarbon, hydrogen is included here unless it is a component of another gas.

### 3.4 Total

#### Sum of Crude oil, NGL and Other

The Total includes crude oil, NGL, refinery feedstocks, additives/oxygenates and other hydrocarbons.

### 3.5 LPG (Liquefied Petroleum Gases)

#### Comprises propane and butane

Liquefied petroleum gas (LPG) is the generic name for commercial propane and commercial butane. It can be produced from natural gas processing plants, oil refineries and in natural gas liquefaction plants as a by-product of the production of liquefied natural gas (LNG). (See figure 3.1 overleaf)

LPG occurs naturally as gas at atmospheric pressure. It has the special property of becoming liquid at atmospheric temperature if moderately compressed and can easily be converted from liquid into gas by being released to atmospheric pressure. In order to facilitate transport and storage, LPG is usually bottled in liquid state (about 250 times more dense than in its gaseous form); propane however can also be supplied in bulk for storage tanks at consumers' premises.

LPG is used domestically, mainly for heating and cooking purposes and industrially for example as feedstock to the petrochemical industry. It is also increasingly used in the transport sector as vehicle fuel, because of its cleaner burning properties and often lower end-use price.

**Figure 3.1: Production of LPG**

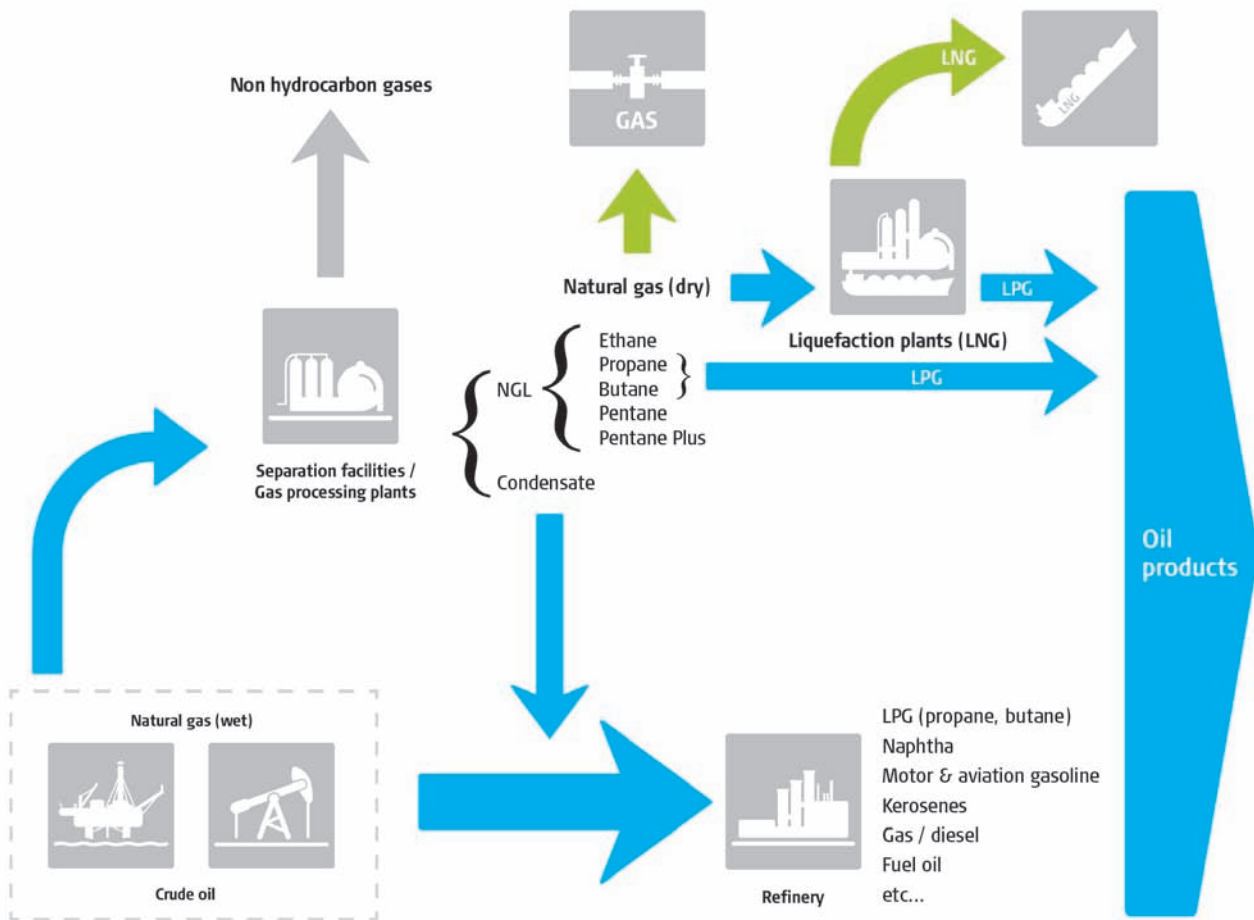

When crude oil and natural gas are produced from the well (either from associated or non-associated wells), they are a mixture of oil, water, sediment and dissolved gases (methane, ethane, propane, butane and pentanes). In the first instance, all gases are separated from the oil/gas mixture **in natural gas processing plants** and separation plants.

The gases are extracted because of their higher value and their readily marketable state, such as propane and butane which are LPG. In a later stage, the sediment and other unwanted substances are removed in treatment plants.

The gases are separated in a wellhead separation plant from onshore and offshore wells respectively. This happens through a separator on the platform. The methane will form the constituent of natural gas, while the others form the **Natural gas liquids (NGL)**. Natural gas liquids however can also be produced in conjunction with natural gas.

Large amounts of LPG are also produced in **petroleum refineries** where they are separated from crude oil in the distillation process.

It is also produced as a by-product of the production of LNG in natural gas liquefaction plants.

## The different definitions used by the six international organisations:

### APEC, Eurostat and IEA:

**LPG** are light paraffinic hydrocarbons derived from the refinery processes, crude oil stabilisation and natural gas processing plants. They consist mainly of propane ( $C_3H_8$ ) and butane ( $C_4H_{10}$ ) or a combination of the two. They could also include propylene, butylenes and isobutylene. LPG are normally liquefied under pressure for transportation and storage.

### OLADE:

**LPG** consists of a mixture of light hydrocarbons which are obtained from petroleum distillation and/or natural gas treatment. The following three types are identified:

- a mixture of hydrocarbons of the  $C_3$  group (propane, propene, propylene);
- a mixture of hydrocarbons of the  $C_4$  group (butane, butene, butylene); and
- a mixture of  $C_3$  and  $C_4$  in any proportions.

### OPEC:

**LPG** is a light hydrocarbons fraction of the paraffin series produced in refineries and gas plants, comprising propane ( $C_3H_8$ ) and butane ( $C_4H_{10}$ ) or a mixture of these two hydrocarbons.

### UNSD:

**LPG** refers to liquefied propane ( $C_3H_8$ ) and butane ( $C_4H_{10}$ ) or mixtures of both. Commercial grades are usually mixtures of the gases with small amounts of propylene, butylene, isobutene and isobutylene stored under pressure in containers.

*Remark:* The mixture of propane and butane used varies according to purpose and season of the year. The gases may be extracted from natural gas at gas separation plants or at plants re-gasifying imported liquefied natural gas. They are also obtained during the refining of crude oil. LPG may be used for heating and as a vehicle fuel. See also the definition for natural gas liquids. Certain oil field practices also use the term LPG to describe the high vapour pressure components of natural gas liquids.

For all organisations LPG comprises mainly propane and butane. LPG from gas plants should be reported to all flows of the JODI Oil questionnaire except refinery output. For further detail please refer to table 4.1 on page 51

## 3.6 Naphtha

**Comprises naphtha used as feedstock for producing high octane gasoline and also as feedstock for the chemical/petrochemical industries**

Naphtha is light or medium oils distilling between 30°C and 210°C which do not meet the specification for motor gasoline.

Different naphthas are distinguished by their density and the content of paraffins, isoparaffins, olefins, naphthenes and aromatics. The main uses for naphthas are as feedstock for high octane gasolines and the manufacture of olefins in the petrochemical industry.

## The different definitions used by the six international organisations:

### APEC, Eurostat and IEA:

**Naphtha** is a feedstock destined for either the petrochemical industry (e.g. ethylene manufacture or aromatics production) or for gasoline production by reforming or isometrisation within the refinery. Naphtha comprises material in the 30°C and 210°C distillation range or part of this range.

### OLADE:

**Definition:** Natural gasoline produced in gas plants and virgin naphtha imported or produced by refineries.

**Description:** It is obtained from the gas treatment plants. In general, natural gasoline is considered as an intermediate or unfinished product, which is used as feedstock for the production of motor gasoline.

**Virgin naphtha:** It is obtained in the primary distillation of oil refineries. The virgin naphtha is a product without chemical transformations that are used as a component in the mixture of gasoline, as input in reforming units, as feedstock in petrochemical plants or exported as oil product. Some countries import virgin naphtha to be used as feedstock in the production of gasoline.

**OPEC:**

**Naphtha:** Refined or partly refined light distillates with an approximate boiling point range of 27 to 221°C. Used as feedstock for catalytic reforming or petrochemical feedstock.

**UNSD:**

**Naphtha:** Light or medium oils distilling between 30°C and 210°C which do not meet the specification for motor gasoline.

*Remark:* Different naphthas are distinguished by their density and the content of paraffins, isoparaffins, olefins, naphthenes and aromatics. The main uses for naphthas are as feedstock for high octane gasolines and the manufacture of olefins in the petrochemical industry.

### 3.7 Motor and aviation gasoline

#### Comprises motor gasoline and aviation gasoline

**Motor gasoline** is the principal fuel used in the transport/road sector and accounts for some 25% of total oil use in the world. In some countries, for example in the US, motor gasoline consumption is almost half of total oil consumption. Motor and aviation gasoline includes also Motor and aviation gasoline oil which has been blended with biogasoline.

Motor gasoline is a complex mixture of relatively volatile hydrocarbons used for spark-ignition internal combustion engines. Gasoline is produced in refineries as the result of primary distillation of crude oil and then further processing, including changing the molecular structure, until the required specifications are met. The characteristics of the gasoline produced depend on the type of crude oil that is used and the setup of the refinery at which it is produced.

Motor gasoline may include some quantities of additives and blending components to improve fuel properties such as octane number, stability and deposit formation in engines.

Gasoline characteristics are also impacted by other ingredients that may be blended into it, such as ethanol. The performance of the gasoline must meet industry standards and environmental regulations that may depend on location.

Motor gasoline may also contain biogasoline products including bioethanol, biomethanol, biobutanol, bio ETBE (ethyl-tertio-butyl-ether), or bio MTBE (methyl-tertio-butyl-ether).

Biogasoline may be blended with petroleum gasoline or used directly in engines. The blending may take place in refineries or at or near the point of sale.

The JODI Oil definition of gasoline also includes **aviation gasoline** which is used in aviation piston engines. Aviation gasoline is a mixture of many different hydrocarbon compounds. The specification requirements for aviation gasoline, especially anti-knock, volatility, fluidity, stability, corrosiveness, and cleanliness impose severe limitations on the compounds that can be used.

#### The different definitions used by the six international organisations:

**APEC, Eurostat and IEA:**

**Motor gasoline** consists of a mixture of light hydrocarbons distilling between 35°C and 215°C. It is used as a fuel for land-based spark ignition engines. Motor gasoline may include additives, oxygenates and octane enhancers, including lead compounds such as TEL (Tetraethyl lead) and TML (tetra methyl lead). This category includes motor gasoline blending components (excluding additives/oxygenates), e.g. alkylates, isometrate, reformate, cracked gasoline destined for use as finished motor gasoline.

**Aviation gasoline:** This is motor spirit prepared especially for aviation piston engines, with an octane number suited to the engine, a freezing point of  $-60^{\circ}\text{C}$  and a distillation range usually within the limits of  $30^{\circ}\text{C}$  and  $180^{\circ}\text{C}$ .

**Biogasoline:** This category includes bioethanol (ethanol produced from biomass and/or the biodegradable fraction of waste), biomethanol (methanol produced from biomass and/or the biodegradable fraction of waste), bioETBE (ethyl-tertio-butyl-ether produced on the basis of bioethanol: the percentage by volume of bioETBE that is calculated as biofuel is 37%) and bioMTBE (methyl-tertio-butyl-ether produced on the basis of biomethanol: the percentage by volume of bioMTBE that is calculated as biofuel is 22%).

#### OLADE:

**Gasoline/Alcohol:** A mixture of light liquid hydrocarbons, obtained from petroleum distillation and/or natural gas treatment, within boiling point range of  $30^{\circ}\text{C}$  to  $200^{\circ}\text{C}$ . It also includes alcohol obtained in distilleries and used as a fuel. This group includes:

**Aviation gasoline:** This is a mixture of reformed high-octane naphthas, which is very volatile and stable, with a low freezing point, used in propeller aircraft with piston engines.

**Motor gasoline:** This is a complex mixture of relatively volatile hydrocarbons, which, with or without additives (such as lead tetraethyl), is used as fuel by internal combustion engines.

**Natural gasoline:** This is a product from natural gas processing. It is used as a raw material for industrial processes (petrochemicals), in refineries, or it is directly mixed with naphthas.

**Alcohol:** This includes both ethanol (ethyl alcohol) and methanol (methyl alcohol) used as fuels.

**Ethanol** is a colourless liquid that may be produced by the fermentation of plant materials with high sugar content, such as sugar-cane syrup or molasses; plant materials with high starch content, such as cassava, corn, etc.; and materials with high cellulose content, such as firewood and plant wastes. It may be used in its anhydrous or hydrated state, alone or mixed with gasoline in internal combustion engines.

**Methanol** is also a colourless liquid that may be produced on the basis of a variety of raw materials, e.g. wood, plant wastes, methane, natural gas, coal. It is used in internal combustion engines.

#### OPEC:

A complex mixture of relative volatile hydrocarbons, with or without small quantities of additives that have been blended to form a fuel suitable for use in internal combustion engines; includes gasoline used in aviation.

#### UNSD:

**Gasoline:** Complex mixtures of volatile hydrocarbons distilling between approximately  $25^{\circ}\text{C}$  and  $220^{\circ}\text{C}$  and consisting of compounds in the  $\text{C}_4$  to  $\text{C}_{12}$  range.

*Remark:* Gasolines may contain blending components of biomass origin, especially oxygenates (mainly ethers and alcohols), and additives may be used to boost certain performance features.

**Motor gasoline:** A mixture of some aromatics (e.g. benzene and toluene) and aliphatic hydrocarbons in the  $\text{C}_5$  to  $\text{C}_{12}$  range. The distillation range is  $25^{\circ}\text{C}$  to  $220^{\circ}\text{C}$ .

*Remark:* Additives are blended to improve octane rating, improve combustion performance, reduce oxidation during storage, maintain cleanliness of the engine and improve capture of pollutants by catalytic converters in the exhaust system. Motor gasoline may also contain biogasoline products.

**Aviation gasoline:** Gasoline prepared especially for aviation piston engines with additives which assure performance under flight conditions. Aviation gasolines are predominantly alkylates (obtained by combining  $\text{C}_4$  and  $\text{C}_5$  isoparaffins with  $\text{C}_3$ ,  $\text{C}_4$  and  $\text{C}_5$  olefins) with the possible addition of more aromatic components including toluene. The distillation range is  $25^{\circ}\text{C}$  to  $170^{\circ}\text{C}$ .

For APEC, Eurostat, IEA, OPEC and UNSD Motor and aviation gasoline comprises aviation gasoline and motor gasoline (including blending components such as bioethanol) – natural gasoline is classified under NGLs. For OLADE gasoline comprises aviation gasoline, motor gasoline, natural gasoline and alcohol (ethanol/methanol) used as fuel. JODI Oil definition does not include pure biofuels used directly in engines.

### 3.8 Kerosenes

#### Comprises kerosene type jet fuel and other kerosene

Mixtures of hydrocarbons in the range  $C_9$  to  $C_{16}$  distilling over the temperature interval 145°C to 300°C, but not usually above 250°C, and with a flash point above 38°C. Kerosenes also include kerosenes which have been blended with bio jet kerosene.

The chemical composition of kerosenes depends on the nature of the crude oils from which they are derived and the refinery processes that they have undergone. Kerosenes obtained from crude oil by atmospheric distillation are known as straight-run kerosenes. Such streams may be treated by a variety of processes to produce kerosenes that are acceptable for blending as jet fuels.

Kerosenes include Other kerosene and Kerosene type jet fuel. Kerosene type jet fuel needs to be reported separately in the category column 9 (of which: Kerosene type jet fuel).

#### Breakdown of kerosene type jet fuel and other kerosene

**Kerosene type jet fuel** is a blend of kerosenes suited to flight conditions with particular specifications, such as freezing point. **Kerosene type jet fuel** is an aviation fuel. The aviation fuels include three types: aviation gasoline (see above Gasoline), gasoline (or naphtha) type jet fuel and kerosene type jet fuel. Kerosene type jet fuel may also include bio jet kerosene.

In terms of demand for the different products, Kerosene type jet fuel has a share of 99% of all aviation fuels and it is the only one basic type of jet fuel in civil use world-wide. The wide-cut gasoline type of jet fuel has not been used by civil aircraft for many years (less than 0.05% of world aviation fuel demand) and, once the fuel for many military organisations, its military use has rapidly decreased over the last few years. Aviation gasoline (included in gasoline) accounts for slightly less than 1% of world aviation fuel demand.

Kerosene type jet fuel is a middle-distillate fuel, generally produced to meet the stringent specifications of international civil specifications, for use as civil aviation fuel. In recent years however, many military organisations, including for example NATO now use fuels which are virtually identical to some of the internationally accepted jet kerosene, mainly differing in the additives included.

Bio jet kerosene is a liquid biofuel derived from biomass and blended with or replacing jet kerosene.

Bio jet kerosene can be produced by a range of thermal processes (including for example gasification followed by Fischer Tropsch synthesis, pyrolysis followed by hydrogenation, or conversion of sugar to hydrocarbons using microorganisms (e.g. yeast). A wide range of biomass feedstocks, including cellulosic materials and algal biomass, could be used in such processes.

**Other kerosene:** Kerosene which is used for heating, cooking, lighting, solvents and internal combustion engines. Other names for this product are burning oil, vaporizing oil, power kerosene and illuminating oil. Lower quality specification kerosene (other kerosene) or a dual purpose grade is used in some regions as domestic heating oil, especially in Asia, notably in Japan and Korea.

Please note that some organisations collect information for jet fuel. Jet fuel includes both kerosene type and naphtha or gasoline type jet fuel. This is not a substantial problem as the latter category barely represents 0.05% of world-wide aviation fuel demand.

#### The different definitions used by the six international organisations:

##### [APEC, Eurostat and IEA:](#)

**Kerosene type jet fuel:** This is a distillate used for aviation turbine power units. It has the same distillation characteristics (between 150°C and 300°C, and generally not above 250°C) and flash point as kerosene. In addition, it has particular specifications (such as freezing point) which are established by the International Air Transport Association (IATA).

**Other kerosene:** Kerosene comprises refined petroleum distillate and is used in sectors other than aircraft transport. It distils between 150°C and 300°C.

#### OLADE:

**Kerosene:** A liquid fuel made up of the oil fraction that is distilled between 150 and 300 degrees C. It is used as a fuel for cooking food, lighting, in motors, in refrigeration equipment, and as a solvent for domestic waxes and insecticides.

#### Jet fuel:

**Definition:** The kerosene used as fuel in reaction motors and turbo propellers.

**Description:** Kerosene with a special degree of refining, with a freezing point below that of common kerosene. It is used in reaction motors and turbo propellers.

#### OPEC:

Comprises Jet fuel and Other Kerosene.

**Jet fuel:** Fuel of naphtha and kerosene type suitable for commercial or military purpose on aircraft turbine engines.

**Other kerosene:** Light hydrocarbon distillates in the 150°C to 280°C distillation range and used as a heating fuel and as fuel for certain types of internal combustion engines.

#### UNSD:

**Kerosenes:** Mixtures of hydrocarbons in the range C<sub>9</sub> to C<sub>16</sub> and distilling over the temperature interval 145°C to 300°C, but not usually above 250°C and with a flash point above 38°C.

*Remark:* The chemical compositions of kerosenes depend on the nature of the crude oils from which they are derived and the refinery processes that they have undergone. Kerosenes obtained from crude oil by atmospheric distillation are known as straight-run kerosenes. Such streams may be treated by a variety of processes to produce kerosenes that are acceptable for blending as jet fuels.

Kerosenes are primarily used as jet fuels. They are also used as domestic heating and cooking fuels, and as solvents. Kerosenes may include components or additives derived from biomass.

**Kerosene-type jet fuel:** A blend of kerosenes suited to flight conditions with particular specifications, such as freezing point.

**Other kerosene:** Kerosene which is used for heating, cooking, lighting, solvents and internal combustion engines. Other names for this product are burning oil, vaporizing oil, power kerosene and illuminating oil.

Kerosene comprises kerosene type jet fuel and other kerosene for all organisations. Kerosene type jet fuel needs to be reported separately in the category column 9 (of which: Kerosene type jet fuel). JODI Oil definition does not include pure biofuels used directly in engines.

### 3.9 Gas/diesel oil

#### For automotive and other purposes

**Gas/diesel oil** is a lighter fuel oil distilled off during the refining process and used primarily for heating, automotive purposes in diesel engines and for power generation. Gas/diesel oil also includes Gas/diesel oil which has been blended with biodiesel.

Two main types are distinguished by their uses:

**Transport diesel:** Fuel used for internal combustion in on-road diesel engines, cars and trucks etc., usually of low sulphur content.

**Heating oil and other gasoil:** This is a distillate fuel oil used mainly in stationary or marine diesel engines. It includes light heating oil which is used for residential or commercial space heating, or in industrial plants. It also includes marine diesel which is used for barge and boat engines and other heavier gas oils which may be used as petrochemical feed stocks.

Demand of **Gas/diesel oil** also includes all Gas/diesel oil which is used as international marine bunker fuel.

**Biodiesels** are liquid biofuels derived from biomass and used in diesel engines.



Biodiesels obtained by chemical modification are a linear alkyl ester made by transesterification of vegetable oils or animal fats with methanol. The transesterification distinguishes biodiesel from straight vegetable and waste oils. Biodiesel has a flash point of around 150°C and a density of about 0.88 kg/litre. Biological sources of biodiesel include, but are not limited to, vegetable oils made from canola (rapeseed), soybeans, corn, oil palm, peanut, or sunflower. Some liquid biofuels (straight vegetable oils) may be used without chemical modification and their use usually requires modification of the engine.

A further category of diesel fuels can be produced by a range of thermal processes (including for example gasification followed by Fischer Tropsch synthesis, pyrolysis followed by hydrogenation, or conversion of sugar to hydrocarbons using microorganisms [e.g. yeast]). A wide range of biomass feedstocks, including cellulosic materials and algal biomass could be used in such processes.

Biodiesels may be blended with petroleum diesel or used directly in diesel engines.

### The different definitions used by the six international organisations:

#### APEC, Eurostat and IEA:

**Gas/diesel oil** is primarily a medium distillate distilling between 180°C and 380°C. Several grades are available depending on use:

- Road Diesel: On road diesel oil for diesel compression ignition (cars, trucks etc.), usually of low sulphur content;
- Heating and other gas oil:
  - Light heating oil for industrial and commercial uses;
  - Marine diesel and diesel used in rail traffic;
  - Other gas oil including heavy gas oils which distil between 380°C and 540°C and which are used as petrochemical feedstocks.

The Gas/diesel oil category includes blending components.

**Biodiesel:** This category includes biodiesel (a methyl-ester produced from vegetable or animal oil, of diesel quality), biodimethylether (dimethylether produced from biomass), Fischer Tropsch (Fischer Tropsch produced from biomass), cold pressed bio oil (oil produced from oil seed through mechanical processing only) and all other liquid biofuels which are added to, or blended.

#### OLADE:

Liquid fuels obtained from atmospheric distillation of petroleum between 200°C and 380°C. It is heavier than kerosene and used in diesel and other compression-ignition engines.

**Diesel oil:** Under this term, you can find the following products:

- Industrial diesel oil;
- Marine diesel for ships;
- Diesel oil for road motor vehicles;
- Gas oil which is a topping or catalytic cracking cut that some countries import or export to achieve a better balance for their refineries.

In some countries industrial or marine diesel is called **gas oil**. This term can also be applied to a fuel that is slightly lighter than diesel oil, suitable for use in tractors and agricultural machinery.

#### OPEC:

**Gas/diesel oil** refers to heavy oils obtained from atmospheric distillation or vacuum redistillation. The viscosity does not exceed 115" Redwood 1 at 38°C.

#### UNSD:

**Gas oil/diesel oil:** Gas oils are middle distillates, predominantly of carbon number range  $C_{11}$  to  $C_{25}$  and with a distillation range of 160°C to 420°C.

*Remark:* The principal marketed products are fuels for diesel engines (diesel oil), heating oils and marine fuel. Gas oils are also used as middle distillate feedstock for the petrochemical industry and as solvents.

Gas/diesel oil for all organisations includes diesel used for transport as well as heating oil and other gas oil. JODI Oil definition does not include pure biofuels used directly in engines.

### 3.10 Fuel oil

#### Heavy residual oil/boiler oil, including bunker oil

Fuel oil is a blended product based on the residues from various refinery distillation and cracking processes. It is a viscous liquid with a characteristic odour and it requires heating for storage and combustion.

Fuel oil is used in medium to large industrial plants, marine applications and power stations in combustion equipment such as boilers, furnaces and diesel engines.

Fuel oil is a general term and other names commonly used to describe this range of products include: residual fuel oil, bunker fuel, bunker C, fuel oil No. 6, industrial fuel oil, marine fuel oil and black oil. Moreover, terms such as heavy fuel oil, medium fuel oil and light fuel oil are used to describe products for industrial applications to give a general indication of the viscosity and density of the product.

Two main categories of fuel oil can be distinguished according to their sulphur content:

- Low sulphur fuel oil: sulphur content is lower than 1%.
- High sulphur fuel oil: sulphur content is 1% or higher.

#### The different definitions used by the six international organisations:

##### APEC, Eurostat and IEA:

This covers all residual (heavy) fuel oils (including those obtained by blending). Kinematic viscosity is above 10 cSt at 80°C. The flash point is always above 50°C and density is always more than 0.90 kg/l.

- **Low sulphur content:** Heavy fuel oil with sulphur content lower than 1%.
- **High sulphur content:** Heavy fuel oil with sulphur content of 1% or higher.

##### OLADE:

This is waste from refining oil, which includes all heavy products and is generally used in boilers, power plants and navigation.

**Fuel oil:** Under this term, various products can be exported or imported. They include among others:

- Industrial fuel oil
- Marine fuel oil for ships
- Heavy fuel oil
- Reduced topping crude oil

##### OPEC:

**Fuel oil** is heavier oils that remain after the distillate fuel oils and lighter hydrocarbons are boiled off in refinery operations. The viscosity is above 115" Redwood 1 at 38°C. It is used for the production of electric power, space heating, vessel bunkering, and various industrial purposes.

##### UNSD:

**Fuel oil:** Comprises residual fuel oil and heavy fuel oil. Residual fuel oils have a distillation range of 350°C to 650°C and a kinematic viscosity in the range 6 to 55 cSt at 100°C. Their flash point is always above 60°C and their specific gravity is above 0.95. Heavy fuel oil is a general term describing a blended product based on the residues from various refinery processes.

*Remark:* Other names commonly used to describe fuel oil include: bunker fuel, bunker C, fuel oil No. 6, industrial fuel oil, marine fuel oil and black oil. Residual and heavy fuel oil are used in medium to large industrial plants, marine applications and power stations in combustion equipment such as boilers, furnaces and diesel engines. Residual fuel oil is also used as fuel within the refinery.

Definitions given are generally comparable and uniformly refer to a high kinematic viscosity, flash point and density of this product. APEC, Eurostat and IEA differentiate additionally according to the sulphur content of this product, whereas OLADE and OPEC differentiate in relation to its use.

### 3.11 Other oil products

#### Refinery gas, ethane, petroleum coke, lubricants, white spirit & SPB, bitumen, paraffin waxes and other oil products

**Refinery gas** includes a mixture of non-condensable gases mainly consisting of hydrogen, methane, ethane and olefins obtained during distillation of crude oil or treatment of oil products (e.g. cracking) in refineries or from nearby petrochemical plants. It is used mainly as a fuel within the refinery.

**Ethane** is a naturally gaseous straight-chain hydrocarbon ( $C_2H_6$ ). It is obtained at gas separation plants or from the refining of crude oil. It is a valuable feedstock for petrochemical manufacture.

**Gasoline type Jet fuel** is composed of light hydrocarbons for use in aviation turbine power units, distilling between 100°C and 250°C. They are obtained by blending kerosenes and gasoline or naphtha in such a way that the aromatic content does not exceed 25% in volume, and the vapour pressure is between 13.7 kPa and 20.6 kPa.

**Petroleum coke** is a black solid obtained mainly by cracking and carbonising heavy hydrocarbon oils and tars and pitches. It consists mainly of carbon (90 to 95%) and has a low ash content.

The two most important categories are "green coke" and "calcined coke".

- Green coke (raw coke) is the primary solid carbonisation product from high boiling hydrocarbon fractions obtained at temperatures below 630°C. It contains 4 -15% by weight of matter that can be released as volatiles during subsequent heat treatment at temperatures up to approximately 1330°C.
- Calcined coke is a petroleum coke or coal-derived pitch coke obtained by heat treatment of green coke to about 1330°C. It will normally have a hydrogen content of less than 0.1% by weight.

In many catalytic operations (e.g. catalytic cracking) carbon or catalytic coke is deposited on the catalyst, thus deactivating it. The catalyst is reactivated by burning off the coke which is used as a fuel in the refining process. The coke is not recoverable in a concentrated form.

**Lubricants** are oils produced from crude oil, for which the principal use is to reduce friction between sliding surfaces and during metal cutting operations. Lubricant base stocks are obtained from vacuum distillates which result from further distillation of the residue from atmospheric distillation of crude oil. The lubricant base stocks are then further processed to produce lubricants with the desired properties.

**White spirit and SBP** (special boiling point industrial spirits) are refined distillate intermediates with a distillation in the naphtha/kerosene range. They are mainly used for non-fuel purposes and sub-divided as:

- **White spirit:** An industrial spirit with a flash point above 30°C. The distillation range of white spirit is 135°C to 200°C.
- **Industrial spirits (SBP):** Light oils distilling between 30°C and 200°C.
- There are 7 or 8 grades of industrial spirits, depending on the position of the cut in the distillation range. The grades are defined according to the temperature difference between the 5% volume and 90% volume distillation points (which is not more than 60°C). White spirit and industrial spirits are mostly used as thinners and solvents.

**Bitumen** is a solid, semi-solid or viscous hydrocarbon with a colloidal structure, being brown to black in colour. It is obtained as a residue in the distillation of crude oil and by vacuum distillation of oil residues from atmospheric distillation. It should not be confused with the non-conventional primary extra heavy oils which may also be referred to as bitumen. In addition to its major use for road pavements, bitumen is also used as an adhesive, a waterproofing agent for roof coverings and as a binder in the manufacture of patent fuel. It may also be used for electricity generation in specially designed power plants. Bitumen is also known in some countries as asphalt but in others asphalt describes the mixture of bitumen and stone aggregate used for road pavements.

**Paraffin waxes** are residues extracted when dewaxing lubricant oils. The waxes have a crystalline structure which varies in fineness according to the grade and are colourless, odourless and translucent, with a melting point above 45°C. Paraffin waxes are also known as petroleum waxes.

**Other petroleum products** include products (including partly refined products) from the refining of crude oil and feedstocks which are not specified above. They will include basic chemicals and organic chemicals destined for use within the refinery or for sale to or processing in the chemical industry such as propylene, benzene, toluene, and xylene.

## The different definitions used by the six international organisations:

### APEC, Eurostat, IEA:

**Refinery gas** includes a mixture of non-condensable gases mainly consisting of hydrogen, methane, ethane and olefins obtained during distillation of crude oil or treatment of oil products (e.g. cracking) in refineries. This also includes gases which are returned from the petrochemical industry.

**Ethane** is a naturally gaseous straight-chain hydrocarbon, (C<sub>2</sub>H<sub>6</sub>) extracted from natural gas and refinery gas streams.

**White spirit and SBP** are defined as refined distillate intermediates with a distillation in the naphtha/kerosene range. They are sub-divided as:

- i. Industrial Spirit (SBP): Light oils distilling between 30°C and 200°C. There are 7 or 8 grades of industrial spirit, depending on the position of the cut in the distillation range. The grades are defined according to the temperature difference between the 5% volume and 90% volume distillation points (which is not more than 60°C).
- ii. White Spirit: Industrial spirit with a flash point above 30°C. The distillation range of white spirit is 135°C to 200°C.

**Lubricants** are hydrocarbons produced from distillate by product; they are mainly used to reduce friction between bearing surfaces. This category includes all finished grades of lubricating oil, from spindle oil to cylinder oil, and those used in greases, including motor oils and all grades of lubricating oil base stocks.

**Petroleum coke** is a black solid by-product, obtained mainly by cracking and carbonising petroleum derived feedstock, vacuum bottoms, tar and pitches in processes such as delayed coking or fluid coking. It consists mainly of carbon (90 to 95%) and has a low ash content. It is used as a feedstock in coke ovens for the steel industry, for heating purposes, for electrode manufacture and for production of chemicals. The two most important qualities are "green coke" and "calcinated coke". This category also includes "catalyst coke" deposited on the catalyst during refining processes; this coke is not recoverable and is usually burned as refinery fuel.

**Bitumen** is a solid, semi-solid or viscous hydrocarbon with a colloidal structure, being brown to black in colour, obtained as a residue in the distillation of crude oil, by vacuum distillation of oil residues from atmospheric distillation. Bitumen is often referred to as asphalt and is primarily used for construction of roads and for roofing material. This category includes fluidized and cut back bitumen.

**Paraffin wax:** These are saturated aliphatic hydrocarbons. These waxes are residues extracted when dewaxing lubricant oils. They have a crystalline structure which is more-or-less fine according to the grade. Their main characteristics are as follows: they are colourless, odourless and translucent, with a melting point above 45°C.

**Other products:** All products not specifically mentioned above, for example: tar and sulphur. This category also includes aromatics (e.g. BTX or benzene, toluene and xylene) and olefins (e.g. propylene) produced within refineries.

### OLADE:

**Refinery gas:** Non-condensable gas obtained from refining crude oil. It consists primarily of hydrogen, methane and ethane used mostly in refining processes.

**Petroleum coke (Oil coke):** Solid and porous fuel, generally black with a high carbon content (90%-95%). It is a residual in oil refining. It is used as input into coke ovens for the steel industry, in the production of electrodes and in the production of chemicals and fuel for heating.

**Non-energy products:** Products with energy content that are not used as fuel such as asphalt, solvents, oils and lubricants.

### OPEC:

**Other Products:** The rest of the products, including white spirit, industrial spirit, paraffin waxes, petroleum coke, etc.

#### UNSD:

**Refinery gas:** Includes a mixture of non-condensable gases mainly consisting of hydrogen, methane, ethane and olefins obtained during distillation of crude oil or treatment of oil products (e.g., cracking) in refineries or from nearby petrochemical plants.

*Remark:* It is used mainly as a fuel within the refinery.

**Ethane:** A naturally gaseous straight-chain hydrocarbon ( $C_2H_6$ ).

*Remark:* Ethane is obtained at gas separation plants or from the refining of crude oil. It is a valuable feedstock for petrochemical manufacture.

**White spirit and special boiling point industrial spirits:** White spirit and special boiling point industrial spirits (SBP) are refined distillate intermediates with a distillation in the naphtha/kerosene range. They are mainly used for non-fuel purposes and sub-divided as: (a) white spirit - an industrial spirit with a flash point above 30°C and a distillation range of 135°C to 200°C; and (b) industrial spirit (SBP) - light oils distilling between 30°C and 200°C.

*Remark:* There are 7 or 8 grades of industrial spirits, depending on the position of the cut in the distillation range. The grades are defined according to the temperature difference between the 5% and 90% volume distillation points (which is not more than 60°C). White spirit and Industrial spirits are mostly used as thinners and solvents.

**Lubricants:** Oils, produced from crude oil, for which the principal use is to reduce friction between sliding surfaces and during metal cutting operations.

*Remark:* Lubricant base stocks are obtained from vacuum distillates which result from further distillation of the residue from atmospheric distillation of crude oil. The lubricant base stocks are then further processed to produce lubricants with the desired properties.

**Paraffin waxes:** Residues extracted when dewaxing lubricant oils. The waxes have a crystalline structure which varies in fineness according to the grade, and are colourless, odourless and translucent, with a melting point above 45°C.

*Remark:* Paraffin waxes are also known as "petroleum waxes".

**Petroleum coke:** Petroleum coke is a black solid obtained mainly by cracking and carbonizing heavy hydrocarbon oils, tars and pitches. It consists mainly of carbon (90 to 95%) and has a low ash content. The two most important categories are "green coke" and "calcined coke".

Green coke (raw coke) is the primary solid carbonization product from high boiling hydrocarbon fractions obtained at temperatures below 630°C. It contains 4-15% by weight of matter that can be released as volatiles during subsequent heat treatment at temperatures up to approximately 1330°C.

Calcined coke is a petroleum coke or coal-derived pitch coke obtained by heat treatment of green coke to about 1330°C. It will normally have a hydrogen content of less than 0.1% by weight.

*Remark:* In many catalytic operations (e.g. catalytic cracking) carbon or catalytic coke is deposited on the catalyst, thus deactivating it. The catalyst is reactivated by burning off the coke which is used as a fuel in the refining process. The coke is not recoverable in a concentrated form.

**Bitumen:** A solid, semi-solid or viscous hydrocarbon with a colloidal structure, being brown to black in color.

*Remark:* It is obtained as a residue in the distillation of crude oil and by vacuum distillation of oil residues from atmospheric distillation. It should not be confused with the nonconventional primary extra heavy oils which may also be referred to as bitumen. In addition to its major use for road pavements, bitumen is also used as an adhesive, a waterproofing agent for roof coverings and as a binder in the manufacture of patent fuel. It may also be used for electricity generation in specially designed power plants. Bitumen is also known in some countries as asphalt but in others asphalt describes the mixture of bitumen and stone aggregate used for road pavements.

### 3.12 Total oil products

**Sum of LPG, Naphtha, Motor and aviation gasoline, Kerosenes, Gas/diesel oil, Fuel oil, and Other oil products.  
Demand for Total oil products includes direct use of crude oil, NGL and Other**

**Total oil products** includes all oil products: the six main product groups described above (LPG Naphtha, Motor and aviation gasoline, Kerosenes, Gas/diesel oil and Fuel oil) as well as products under Other oil products: refinery gas, ethane, gasoline type jet fuel, petroleum coke, white spirit & SBP, paraffin waxes, bitumen, lubricants and other products.

Total oil products is the sum of the products.

Double counting should be avoided. For example, if additives and oxygenates (e.g. ethanol or biofuels) are included with gasoline (APEC, Eurostat/IEA and OLADE) then these products should not be added again to the Total Oil Products category. This is similar to the treatment of natural gasoline, if it was already accounted for under gasoline.



# Chapter 4: Flow Definitions

## 4.1 Production (Total : Crude oil/NGL/Other)

**Marketable production after removal of impurities but including quantities consumed by the producer in the production process**

### Crude oil production

In the JODI Oil questionnaire, production only applies to Crude oil, NGL, Other and Total. Production of refinery products is refinery output (see 4.10 Refinery output).

Production is the removal of oil from the field, whether through primary or secondary recovery. Although this concept sounds simple, there are many different items that can be included or excluded when reporting crude oil production. The main differences however are between wellhead production and marketable production.

**Wellhead production** is all oil which exits the ground (wellhead). When the crude oil is brought to the surface, it requires further treatment so that it can be sent to refineries for processing. The oil produced at the well-head varies considerably from field to field, due not only to the physical characteristics, but also to the amount of gas and water which it contains. Before the oil can be sold, the remaining gas, water and other impurities need to be removed. Once this is done, the oil is stored at the terminal before transport to refineries. It is at this point that the produced oil becomes marketable (production).

Figure 4.1: Wellhead versus marketable production

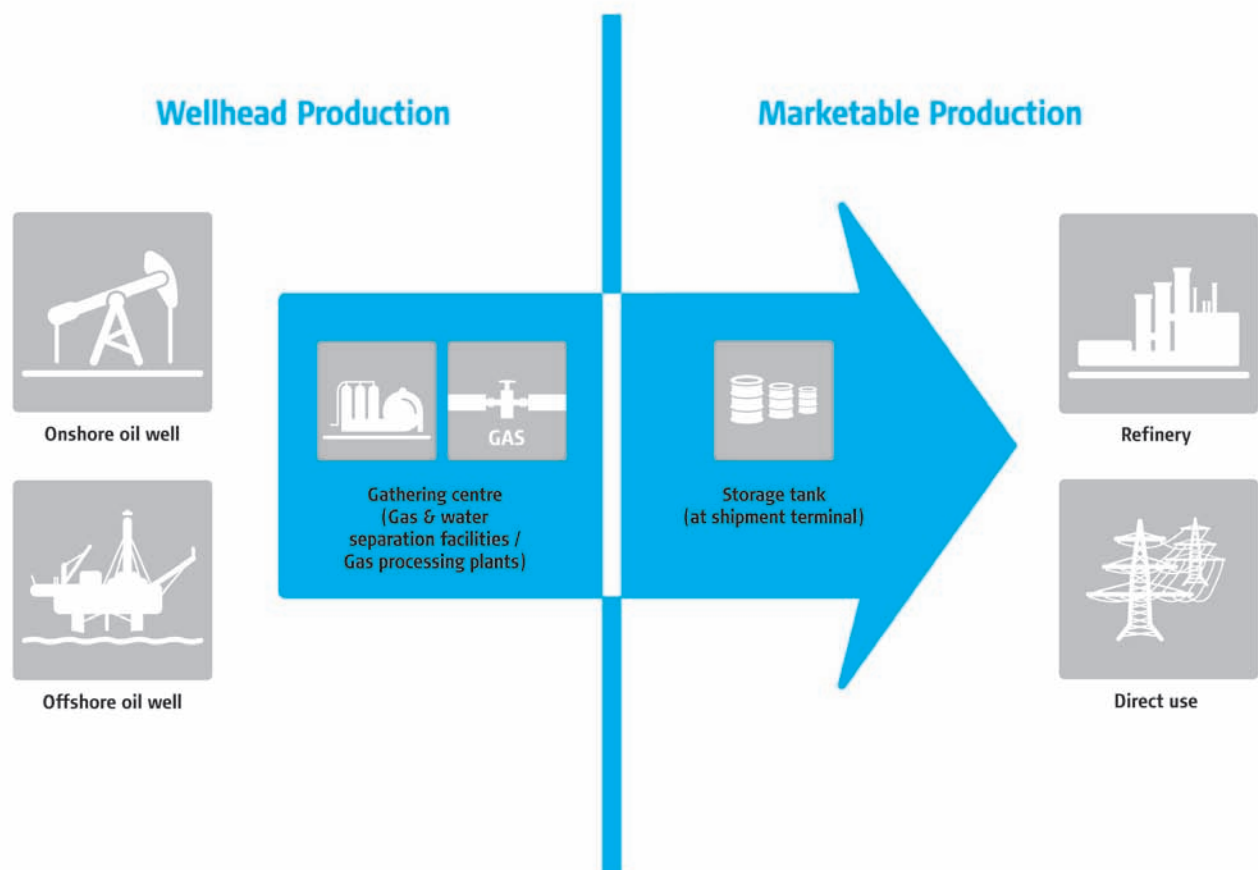



**Note:** Production of synthetic crude oils from extra heavy oils, oil sands and oil shale should be reported here. Production of emulsified oils such as orimulsion should also be reported as Production while the production of synthetic oils from coal and natural gas should be reported in "From other sources". See next section.

### The different definitions used by the six international organisations:

#### APEC, Eurostat and IEA:

**Production** within national boundaries including off-shore production. Production should only include marketable production, excluding volumes returned to formation. Such production should include all crude oil, NGL, condensates and oil from shale and tar sands, etc. It should also include the receipts of additives/oxygenates by refineries and blending plants from outside the refinery sector.

#### OLADE:

**Primary energy production:** All energy extracted, exploited, harvested, etc., is considered to be of importance to the country as evidently it has been produced within the national territory.

#### OPEC:

**Production** volumes reported as crude oil include total crude oil coming out of degassing or treatment plants directly received or measured at storage facilities including shares from joint fields.

**Natural Gas Liquids Production:** NGL are those portions of reservoir gas which are liquefied at the surface in lease separators, field facilities or gas processing plants. NGL include but are not limited to: ethane, propane, butane, natural gasoline and condensate. Field or lease condensate is a natural gas liquid recovered from gas-well gas (associated or non-associated) in lease separators or field facilities. It consists primarily of pentanes and heavier hydrocarbons. Plant condensates is one of the natural gas plant products, mostly pentanes and heavier, recovered and separated as liquids at gas inlet separators or scrubbers in processing plants or field facilities. Gas plant LPG is the mixture of C<sub>3</sub> and C<sub>4</sub> hydrocarbons which are extracted from wet natural gases and are mainly composed of:

- Propane (C<sub>3</sub>H<sub>8</sub>): Is a gaseous paraffinic compound;
- Butane (C<sub>4</sub>H<sub>10</sub>): Is a mixture of two gaseous paraffins, normal butane and isobutene.

**Other (Non-conventional oil production):** Non-conventional oil includes synthetic crude oil from tar sands, oil shale, etc., liquids derived from coal liquefaction (CTL) and gas liquefaction (GTL), hydrogen and emulsified oils (e.g. Orimulsion), non-hydrocarbon compounds added to or blended with a product to modify fuel properties (octane, cetane, cold properties, etc.) e.g. alcohols (methanol, ethanol), ethers (such as MTBE (methyl tertiary butyl ether), ETBE (ethyl tertiary butyl ether), TAME (tertiary amyl methyl ether) or ethers (e.g. rapeseed or dimethylester, etc.) and chemical compounds such as TML (tetramethyl lead) or TEL (tetraethyl lead) and detergents.

#### UNSD:

**Production** is defined as the capture, extraction or manufacture of fuels or energy in forms which are ready for general use. In energy statistics, two types of production are distinguished, primary and secondary. Primary production is the capture or extraction of fuels or energy from natural energy flows, the biosphere and natural reserves of fossil fuels within the national territory in a form suitable for use. Inert matter removed from the extracted fuels and quantities reinjected, flared or vented are not included. The resulting products are referred to as "primary" products.

Secondary production is the manufacture of energy products through the process of transformation of primary fuels or energy. The quantities of secondary fuels reported as production include quantities lost through venting and flaring during and after production. In this manner, the mass, energy and carbon within the primary source(s) from which the fuels are manufactured may be balanced against the secondary fuels produced. Fuels, electricity and heat produced are usually sold but may be partly or entirely consumed by the producer.

The term production is defined differently by the 6 organisations according to either more general or more specific energy or fuel reporting. APEC, Eurostat and IEA use the term for all liquid production i.e. crude oil, NGL condensates and oil from shale and tar sands as well as additives/ oxygenates. The definition of production in OLADE is used for all energy production, for UNSD it is used for all energy as well as more specifically for crude oil and refined products.

## 4.2 From other sources

**Inputs of additives, biofuels and other hydrocarbons that are produced from non-oil sources such as: coal, natural gas or renewables**

Additions to the supply of an energy product that have already been accounted for in the production of another energy form.

An example is the blending of liquid biofuels with motor gasoline, kerosene-type jet fuel and gas oil/diesel oil.

## 4.3 Imports and exports

**Goods having physically crossed the national boundaries excluding transit trade. Exports should exclude international marine and aviation bunkers.**

The trading of oil (both crude oil and oil products) raises a number of issues for reporting statistics of imports and exports:

- the concept of national territory;
- the notion of customs clearance;
- transit trade;
- international marine and aviation bunkers.

Both imports and exports should reflect amounts of oil having **crossed the national territorial boundaries**. It is therefore essential that there is a clear definition of what the statistical national boundary of the country is.

Trade figures should report **physical flows** of oil and oil products. To that extent, customs clearance which sometimes is delivered long after the goods have crossed the national frontier should not be taken as the point of registering the import.

The trade figures however are often derived from customs statistics, which take the customs clearance as the indicator for import or export. In the absence of other trade reporting systems customs statistics should be used.

Imports of crude oil and petroleum products, in order to be consistent with major economic indicators, should be at least partly for domestic use. This implies that quantities passing through a country "**in transit**" **should not be included** in the import and export figures. Please note that if crude oil is imported to be refined in the country, and the products resulting from this process are exported (processing agreement), this is not considered as transit trade. Therefore, the quantities of crude oil imported for this purpose should be reported as an import and the resulting products which will be sold to another country should be reported as an export.

Deliveries of oil to ships for consumption during international voyages (**international marine bunkers**) or aviation fuels delivered for international flights (**international aviation bunkers**) should not be included in the export figures. International bunkers are fuels which are delivered to vessels or aircraft, irrespective of the country of registration, which are undertaking international voyages. The oil delivered as bunkers is to be used as fuel by the ship or aircraft and not as part of the cargo.

Although the fuels delivered for these purposes will be leaving the national boundaries of the country, they should **not be reported as exports**. For the purpose of the JODI Oil questionnaire, the international marine and aviation bunkers are to be included in the demand figures. The reason for this is that in the JODI Oil questionnaire, we try to monitor the total demand for oil including refinery fuel and bunkers (see Section 4.14 Demand).

## The different definitions used by the six international organisations:

### APEC:

**Imports and Exports:** Quantity of fuels obtained from or supplied to other countries. Amounts are considered as imported or exported when they have crossed the political boundary of the country, whether customs clearance has taken place or not. The amount of fuels in transit (that is, on route through the country) should not be included.

### Eurostat/IEA:

**Imports and Exports:** Data should reflect amounts having crossed the national territorial boundaries, whether customs clearance has taken place or not. Quantities of crude oil and products imported or exported under processing agreements (i.e. refining on account) should be included.

Crude oil and NGL's should be reported as coming from the country of ultimate origin; refinery feedstock and finished products should be reported as coming from the country of last consignment. Any gas liquids (e.g. LPG) extracted during the regasification of imported liquefied natural gas should be included as imports.

Petroleum products imported or exported directly by the petrochemical industry should be included.

Re-exports of oil imported for processing within bonded areas should be included as an export of product from the processing country to the final destination.

**Note:** Imports or exports of ethanol (reported as a part of Additives/Oxygenate under category Other) should relate to the quantities destined for fuel use.

### OLADE:

**Imports:** Includes all primary and secondary energy sources originating from outside the borders and entering the country to make up a part of the total energy supply system.

**Exports:** The amount of primary and secondary energy that a country allots to foreign trade.

**Note:** Some countries follow the practice of considering the aviation gasoline and retrofuel sold to foreign aircraft, as well as the bunker sold to foreign ships as exports. OLADE does not recommend this procedure, because in order to be consistent, it would have to record what domestic ships and craft load abroad as imports.

According to OLADE's conception, the amount purchased by a consumer within a country is assumed to be part of final consumption although the physical process of consumption may take place in international spaces or waters. The same occurs when a vehicle loads gasoline in one country and then crosses the border and consumes it in a neighbouring country.

### OPEC:

**Imports and Exports** comprise amounts having crossed the national territorial boundaries of the country whether or not customs clearance has taken place. Quantities of crude oil and oil products imported or exported under processing agreements (i.e. refining on account) are included. Quantities of oil in transit are excluded.

Crude oil and NGL are reported as coming from the country of origin; refinery feedstocks and oil products are reported as coming from the country of last consignment. Re export of oil imported for processing within bonded areas are shown as an export of product from the processing country to the final destination.

### UNSD:

**Imports** of energy products comprise all fuel and other energy products entering the national territory. Goods simply being transported through a country (goods in transit) and goods temporarily admitted are excluded but re-imports, which are domestic goods exported but subsequently readmitted, are included. The bunkering of fuel outside the reference territory by national merchant ships and civil aircraft engaged in international travel is excluded from imports. Fuels delivered to national merchant ships and civil aircraft which are outside of the national territory and are engaged in international travel should be classified as "International Marine" or "Aviation Bunkers", respectively, in the country where such bunkering is carried out.

**Exports** of energy products comprise all fuel and other energy products leaving the national territory with the exception that exports exclude quantities of fuels delivered for use by merchant (including passenger) ships and civil aircraft, of all nationalities, during international transport of goods and passengers. Goods simply being transported through a country (goods in transit) and goods temporarily withdrawn are excluded but re-exports, foreign goods exported in the same state as previously imported, are included. Fuels delivered to foreign merchant ships and civil aircraft engaged in international travel are classified as "International Marine" or "Aviation Bunkers", respectively.

Trade definitions are common to all organisations, and emphasise the crossing of national territory whether or not customs clearance has taken place and the exclusion of oil in transit quantities. Crude oil and NGL are reported as coming from the country of ultimate origin. Refinery feedstocks and finished products are reported as coming from the country of last consignment. International bunkers are excluded from exports and are reported in oil demand.

#### 4.4 Products transferred/Backflows

##### **Sum of products transferred and backflows from the petrochemical industry**

Backflows from the petrochemical sector to refineries are finished or semi-finished products which are returned from final consumers to refineries for processing, blending or sale.

Petrochemical plants convert hydrocarbon feedstock into organic chemicals, intermediate compounds and finished products such as plastics, fibres, solvents and surfactants.

Feedstock used by the plant is usually obtained from the refinery and includes naphtha, ethane, propane and middle distillate oils (for example, gas oil). The carbon and hydrogen in the feedstock is largely transferred to the basic chemicals and products subsequently made from them. However, certain byproducts are also created and returned to the refinery (such as pyrolysis gasoline).

For integrated petrochemical industries this flow should be estimated. Transfers from one refinery to another within the country should be excluded.

Products transferred are usually imported petroleum products which are reclassified as feedstocks for further processing in the refinery, without delivery to final consumers. For example, Naphtha imported for upgrading would be first reported as Imports of Naphtha, and then appeared also as Products transferred of Naphtha.

#### 4.5 Direct use

##### **Use of oils without being processed in oil refineries, for example: crude oil burned for electricity generation**

Crude oil, NGL and Other which are used directly without being processed in oil refineries are reported as direct use. This includes, for example, crude oil burned for electricity generation.

The amount reported under Crude oil, NGL or Other should be also reported to Receipts of other oil products.

## 4.6 Stock change

**Closing minus opening level**  
**A positive number indicates a stock build during the period**  
**A negative number indicates a stock draw during the period**

As for stock levels, only changes in primary oil stocks of crude and products should be reported.

**Stock change is calculated as the closing stock level minus the opening stock level.**

**Opening stock level** is the amount of primary stocks on national territory, measured on the first day of the month being reported (e.g. 1st June).

**Closing stock** is the amount of primary stocks on national territory measured on the last day of the month being reported (e.g. 30th June). Stock changes is closing – opening stock level: therefore, a stock build is shown as a positive number, and a stock draw as a negative number.

Please note that in some other reporting systems, the stock changes are opening minus closing levels. A stock build is then shown as a negative number and a stock draw as a positive number. There is no unanimity about which calculation to use. However, the international oil industry is in general using the JODI Oil definition mentioned above.

**The different definitions used by the six international organisations:**

**APEC, Eurostat, and IEA:**

Stock changes should reflect the difference between closing stock level and opening stock level for stocks held on national territory.

A stock build is shown as a positive number, and a stock draw as a negative number.

**OLADE:**

**Inventory variation** is the difference between initial stocks and final stocks in the storage facilities for different products. Inventory variation is considered according to its nature. Thus, an inventory increase means a reduction in the total supply and vice-versa.

**Oil and derivatives inventory variation**

The location of storage tanks where inventory variations are caused and are mentioned below are valid for oil, liquefied gas, gasoline/alcohol, diesel oil, fuel oil, other secondary products, and non-energy sources.

- Ports that control import and export movements
- Oil producing reservoirs
- Refineries, where crude oil is transformed into derivatives
- Gas treatment centres, where condensables such as natural gasoline and liquefied gas are extracted from natural gas
- Power plants that use diesel oil and fuel oil as raw materials

**OPEC:**

**Stock changes** reflect the difference between closing levels on the last day of the period and opening stock levels on the first day of the period of stocks on national territory held by producers, importers, energy transformation industries and large consumers. A stock build is shown as a positive number, and a stock draw as a negative number.

**UNSD:**

**Stock changes** are defined as the increase (stock build) or decrease (stock draw) in the quantity of stock over the reporting period. They are calculated as a difference between the closing and opening.

## 4.7 Statistical difference

### Differences between observed supply flows and calculated Refinery intake or Demand

#### Primary supply

- Statistical Difference =
- + Production
  - + From other sources
  - + Imports
  - Exports
  - + Products Transferred/Backflows
  - Direct use
  - Stock change
  - Refinery intake

#### Secondary oil products supply

- Statistical Difference =
- + Refinery Output
  - + Receipts
  - + Imports
  - Exports
  - Products Transferred
  - + Interproduct Transfers
  - Stock change
  - Demand

## 4.8 Refinery intake

### Observed refinery throughputs

In this flow the quantities of crude oil and several other inputs including Natural Gas Liquids (NGL), refinery feedstocks, additives, biofuels and other hydrocarbons inputs entering the refinery should be reported. Please note that the volume of crude oil and other inputs reported as refinery intake should reflect the real quantities of inputs to the refinery process and not the deliveries of crude oil to the refinery. The difference between the two measures is the stock changes of crude oil at the refinery. See Figure 4.2 on page 50 for a chart of the main refinery flows.

#### The different definitions used by the six international organisations:

##### APEC, Eurostat and IEA:

This is defined as the total amount of oil (including other hydrocarbons and additives) observed to have entered the refinery process.

##### OLADE:

Amount of crude oil loaded in the primary distilling unit of refineries, from which flow intermediate currents that are processed in the conversion units. The main ones are:

- a) Reforming: increases the octanes of gasolines
- b) Cracking: increases both the octanes and yield of gasolines
- c) Hydrocracking: increases the yield of diesel and improves its cetane index
- d) Vacuum: distilling at a very low pressure to separate into two fractions the reduced crude oil from primary distilling
- e) Viscosity reducer: improves the viscosity of fuel oil
- f) Coking: increases the amount of gasoline beyond what cracking does, but as the octanes are very low, it requires reforming.
- g) Flexicoking: increases even more the yield of gasoline and liquefied gas
- h) Isomerization/polymerization: increases the octanes of gasolines beyond reformation and cracking, especially for aviation.

#### OPEC:

Total input of crude, NGL, condensates and feedstocks to atmospheric crude distillation unit.

#### UNSD:

**Refinery intake** refers to the amount of oil (including other hydrocarbons and additives) that has entered the refinery process.

The Refinery Intake definition, according to all organisations, comprises crude oil, NGL, condensates, feedstocks and additives.

### 4.9 Closing stocks

**Represents the primary stock level at the end of the month within national territories; includes stocks held by importers, refiners, stock holding organisations and governments**

Oil stocks are a critical element of information in an oil balance. The majority of oil stocks are essential to keep the global supply system operating. There is oil in pipelines going from the wellhead production sites to refineries, from refineries to consumers. Stocks are also held in tankers, railcars and road tankers linking production sites, refineries and consumers.

Not to include stock data in an oil balance leads to a lack of transparency in the market. The trend in stocks is important for many oil analysts when making an evaluation of the oil market situation.

Stocks are a leading indicator of price movements: the level of oil stocks often determines the price, e.g. when oil stocks are low it means that there may be a shortage or a need for replenishing, which indicates that prices will be rising. On the other hand if the industry is amply supplied with the right oil, there may be a price reduction expected. This is why it is important to have information on the situation of oil stocks in the world.

Information on product stocks can be as important as crude oil stocks. For example, crude oil stocks give an indication of the availability of crude to refineries in each country, and therefore, are evidence of how well the refineries might provide the domestic market. On the other hand, information on low gasoline stocks before the driving season, or low heating oil stocks before the winter can be a warning signal to refineries, oil companies and governments that shortages might possibly occur (e.g. heating oil problems experienced in autumn of 2000).

Another relevant point is that data on oil stocks can be particularly important for strategic decisions, made by governments or larger oil companies. They need aggregate and timely stock information in order to look at their longer term planning, to ensure adequate supplies to meet projected demand. Governments also require extensive stock information so that they can react appropriately when oil supply disruptions (both national and international) occur.

#### 4.9.1 What are primary, secondary and tertiary stocks?

*Please note that when referring to stock data, the terms primary and secondary are often used in a different context from when talking about primary and secondary products as commodities in an energy balance.*

**Primary stocks** are held by the various companies supplying the market: ranging from producers to refiners to importers. They are held in refinery tanks, bulk terminals, pipeline tankage, barges and coastal tankers (if they stay in the same country), tankers in port (if they are to be discharged at port) and in inland ship bunkers. Additionally stocks held for strategic purposes by governments (e.g. US SPR) or by stockholding organisations (e.g. EBV in Germany) are included in the primary stock category.

**Secondary stocks** are stocks in small bulk plants (marketing facilities below a certain capacity e.g. 50,000 bl in US, which receive their product by rail or truck) and retail establishments.

**Tertiary stocks** are stocks held by final end-consumers. They can be power plants, industrial entities or consumers in the residential/commercial sector.

#### 4.9.2 What data should be collected?

**Only data on primary oil stocks (both crude oil and products) should be reported in the JODI Oil questionnaire, for several reasons:**

- The **most important data** on stocks are primary oil stocks. These are stocks held by producers, refiners, importers, stock holding organisations and strategic stocks. The oil in pipelines or in rail tank cars, in road tank wagons etc. which are necessary to keep the supply system operational are of lesser interest – they cannot be used as otherwise the supply system would break down.
- Data on primary oil stocks is the **easiest to collect**. Data for secondary and tertiary stocks are rarely collected, as they are very difficult to obtain. The reason for this is that there are often too many retail stations, or small bulk plants in the country, and certainly the number of end-users from which data would need to be collected is enormous. However, despite the lack of information, secondary and tertiary stocks can be very important as they sometimes undergo large fluctuations, e.g. household heating oil tanks are rapidly depleted when weather is cold; retail stations stocks can be considerably run down when a tax increase is expected. Please note that terminology can differ in some countries, where no distinction is made between secondary and tertiary stocks and both categories are aggregated into secondary stocks.
- Information on primary oil stocks is **consistent** with the definition of "consumption" or to be more precise, "sales", which includes only sales or deliveries made by refineries and importers (i.e. primary suppliers); secondary and tertiary stocks should not be included.
- Primary oil stocks also represent storage of oil at a more centralised point in the supply chain, where it is feasible for them to be redirected. This is particularly important for oil importing countries during supply disruptions, as they need to know the potential volume of oil available to them. An example of these stocks is oil held at terminals, or in partly loaded tankers.

**The following table lists the main categories to be included or excluded under Primary Oil Stocks (both crude oil and products):**

What should be included? *	What should not be included?
<ul style="list-style-type: none"> <li>✓ Oil held at production facilities e.g. stocks on platforms or in partly loaded tankers moored at platforms</li> <li>✓ Stocks held for strategic purposes owned by governments or stockholding organisations</li> <li>✓ Oil in refinery tanks</li> <li>✓ In bulk terminals</li> <li>✓ Pipeline tankage (buffer stocks at pipelines)</li> <li>✓ Barges and coastal tankers (when port of departure and destination are in the same country)</li> <li>✓ Tankers in port **</li> <li>✓ In inland ship bunkers</li> </ul>	<ul style="list-style-type: none"> <li>✗ in pipelines</li> <li>✗ in rail tank cars</li> <li>✗ in truck tank cars</li> <li>✗ in sea-going ships bunkers</li> <li>✗ in retail stores and service stations</li> <li>✗ in bunkers at sea</li> <li>✗ military stocks</li> </ul>

\* Please note that there is a distinction between oil stocks and reserves. Reserves of oil (oil not yet produced) are not included.

\*\* Stocks held on board incoming ocean vessels in port or at mooring should be included irrespective of whether they have been cleared by customs or not. Exclude stocks on board vessels at high sea.



### 4.9.3 Location of stocks

**Stocks are to be reported on a national territory basis:** All oil held within a country geographically is to be reported, irrespective of the ownership of the oil. For example, oil held in the Netherlands ARA zone (Amsterdam – Rotterdam - Antwerp) for the benefit of German companies is to be included in the Netherlands report, not in the German oil stocks.

Whether the stocks are held onshore or offshore does not make a difference as long as they are held on the national territory.

### 4.9.4 Timing / Cut-off date

Stocks of crude oil and petroleum products are volumes in storage at a particular time. For oil stocks to be consistent data with other oil flows, a monthly basis is chosen. As an example, sales of oil products are reported on a monthly calendar basis. That is why it is important to also measure stocks on a monthly basis. Stocks are therefore considered at the beginning i.e. 1st day of the month (Opening stocks) and end of each month, i.e. on 28/29/30 or 31<sup>st</sup> of the month (Closing stocks).

### 4.9.5 Availability of stocks data

Most JODI participating countries now make stock data freely available. They fully value the strategic importance of all data gathered through the JODI Oil questionnaire on micro and macro levels. However, they equally recognize the importance of the global effort to enhance energy commodity transparency and to mitigate some of uncertainties that may be detrimental to market functionality. Nevertheless, some countries still hold the view that such data is strategically or commercially sensitive.

The nature of the stock data requested in the JODI Oil questionnaire is designed to avoid commercial sensitivities with reporting being limited to the national level and at an aggregate degree of detail. As the focus of JODI is on oil stocks collected at a national level there is little basis for such concern.

The ultimate goal of the Joint Organisations Data Initiative is full transparency. However, this hinges on the willingness of all countries to submit timely and accurate data for all products and all flows, including stock changes and levels. Given that timely and complete data on oil stock levels and stock changes are essential elements of the accurate analysis necessary to mitigate uncertainty, both at national and international market levels, it is a JODI priority to encourage universal transparency of stock data.

## The different definitions used by the six international organisations:

### APEC, Eurostat and IEA:

**Total stocks on national territory:** All stocks on national territory, including stocks held by governments, by major consumers or by stockholding organisations, stocks held on board incoming ocean vessels, stocks held in bonded areas and stocks held for others, whether under bilateral government agreement or not.

### OLADE:

**Stocks:** quantities of energy products that can be held and used to: (a) maintain service under conditions where supply and demand are variable in their timing or amount due to normal market fluctuations, or (b) supplement supply in the case of a supply disruption. Stocks used to manage a supply disruption may be called "strategic" or "emergency" stocks and are often held separately from stocks designed to meet normal market fluctuations.

### OPEC:

**Stocks** include all nationally owned crude oil, refined products and gas plant products held within and outside national boundaries (on shore as well as floating) held by importers, governments, national oil companies and major non-importing final consumers in the following facilities; bulk terminals, refinery tanks, pipeline tankage, barges and tankers.

### UNSD:

**Stocks:** quantities of energy products that can be held and used to: (a) maintain service under conditions where supply and demand are variable in their timing or amount due to normal market fluctuations, or (b) supplement supply in the case of a supply disruption. Stocks used to manage a supply disruption may be called "strategic" or "emergency" stocks and are often held separately from stocks designed to meet normal market fluctuations.

For all the organisations, the definition for stocks is defined "geographically" or "by territory" except for OPEC where it is characterised by the "ownership".

## 4.10 Refinery output

### Gross output (including refinery fuel)

#### Refinery production

This is the production of finished petroleum products at a refining or blending plant. Production equals the Input into the refinery minus the Refinery Losses.

The terms Net and Gross production are frequently used when referring to refinery output. **Gross production** includes the amount of fuel which is used in the refinery in support of the operation of the refinery (refinery fuel). **Net refinery production** excludes the refinery fuel.

If for any reason, interproduct transfer cannot be separated from the refinery output data, data providers should indicate whether the interproduct transfers are included in the refinery production or not.

Figure 4.2: Main refinery flows

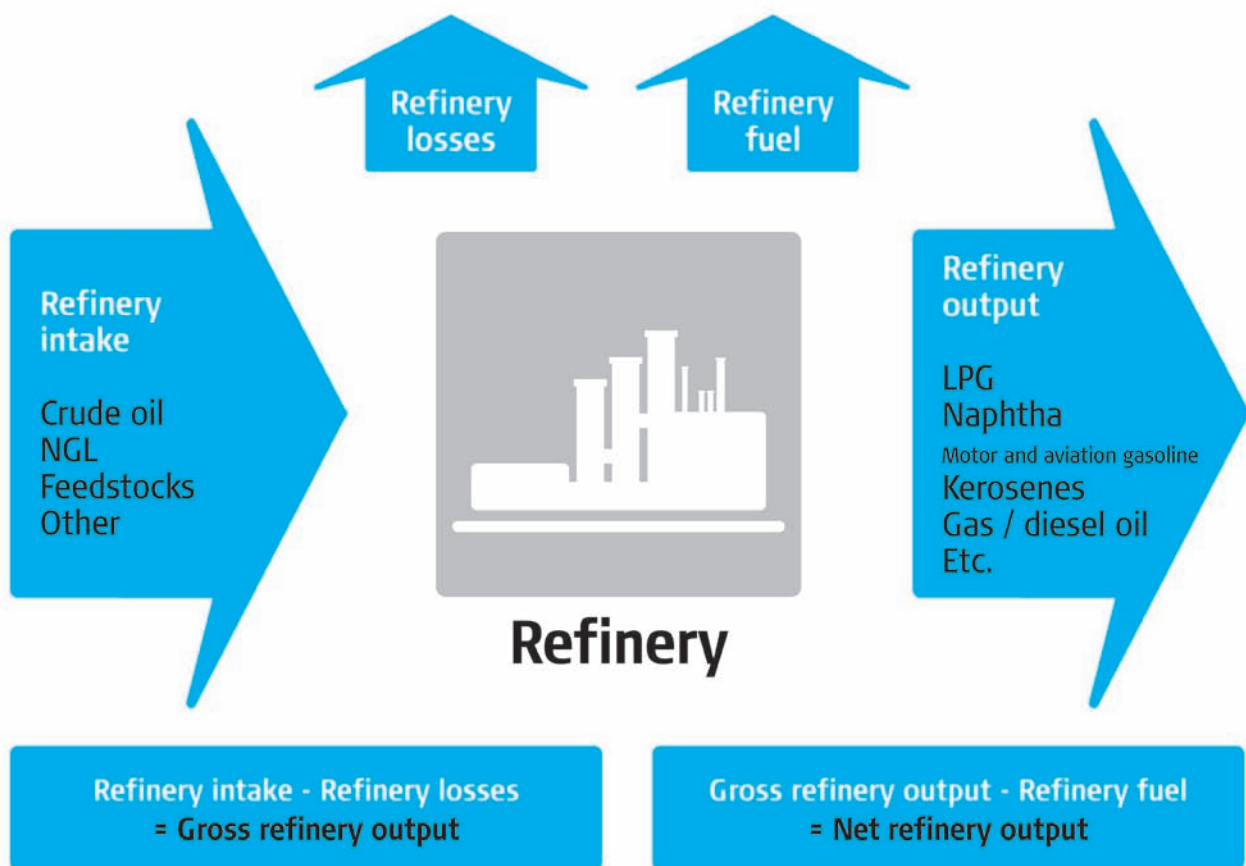

**The different definitions used by the six international organisations:**

**APEC, Eurostat and IEA:**

**Gross refinery output:** This is production of finished products at a refinery or blending plant. This category excludes Refinery Losses, but includes Refinery Fuel. The total must be equal to Refinery Intake (Observed) minus Refinery Losses.

**Refinery Fuel:** These are all petroleum products consumed in support of the operation of a refinery. This should not include products used by oil companies outside the refining process, e.g. bunkers for oil tankers.

**OLADE:**

This description is valid for products such as gases, liquefied gas, gasoline/alcohol, kerosene, diesel oil, fuel oil, coke, other secondary products and non energy products in refineries.

For each product, the amount produced by all refineries, in the national territory, should be recorded. If any part of the products produced in one refinery is recycled in another, that amount should be subtracted from what will be considered production.

The primary products obtained from a refinery are:

- gases: refinery gas (C<sub>1</sub>-C<sub>2</sub>) and liquefied gas (C<sub>3</sub>-C<sub>4</sub>)
- light: motor gasoline, aviation gasoline, naphthas for petrochemistry, solvents
- medium: kerosene, jet fuel, gas oil, diesel oil
- heavy: fuel oil, asphalts, lubricants, greases, coke

#### OPEC:

The total amount of petroleum products produced from refinery input in a given period, excluding refinery fuel and loss.

**Refinery fuel and loss:** The total amount of finished or unfinished products used in refineries as fuel, or lost during refinery operation through spillage, evaporation and venting.

#### UNSD:

**Refinery output** refers to the marketable end-products of the refinery process excluding refinery losses but including the quantity of fuels consumed at refineries (refinery fuel used in the actual refining process and the fuels used for other ancillary purposes).

APEC, Eurostat, IEA and UNSD exclude refinery loss but include refinery fuel. OPEC excludes both. The OLADE definition does not mention anything about refinery fuel or loss. Interproduct transfers are excluded by all organisations except OLADE.

### 4.11 Receipts

#### Receipts = Primary product receipts and Recycled products

**Primary product receipts:** Quantities of indigenous or imported crude oil (including condensate) and indigenous NGL which are used directly without being processed in a petroleum refinery. For example, crude oil used to generate electricity should be reported as Direct use of crude oil and Receipts of Other products.

Quantities of indigenous NGL which are not included in Refinery intake, such as the amounts going to a gas plant, should be reported as Receipts of Other products, and then transferred through the Interproduct transfers line to the allocated product type.

Table 4.1: Example 1 of reporting Direct use of NGL

	NGL		Oil products	
			LPG	Other oil products
	(2)		(11)	(12)
+ Production	100 (of which 50)	+ Refinery output	10	
+ From other sources		+ Receipts		50
+ Imports	25	+ Imports		
- Exports		- Exports	5	
+ Products transferred /Backflows		- Products transferred		
- Direct use	50	+ Interproduct transfers	50	-50
- Stock change	6	- Stock change	2	
- Statistical difference	4	- Statistical difference	-2	0
= Refinery intake	65	= Demand	55	
Closing Stocks		Closing stocks		

**Recycled products:** The return of a delivered product to supply without reclassification as another product. An example is the recovery of used lubricants. These quantities should be distinguished from petrochemical Backflows.

#### 4.12 Products transferred

**Petroleum products which are reclassified as feedstocks for further processing in the refinery, without delivery to final consumers**

The reclassification (renaming) of oil products which is necessary when finished oil products are used as feedstock in refineries.

These are usually imported petroleum products which are reclassified as feedstocks for further processing in the refinery, without delivery to final consumers. For example, Naphtha imported for upgrading would be first reported as Imports of Naphtha, and then appears also as Products transferred of Naphtha.

#### 4.13 Interproduct transfers

**Reclassification of products, because their specification has changed, or because they are blended into another product: a negative indicates a product that will be reclassified, a positive shows a reclassified product**

The movements of fuels between product categories because of reclassification of a product which no longer meets its original specification. The transferred product is often blended with its host.

Result from reclassification of products either because their specification has changed, or because they are blended into another product. For example, quantities of Kerosene may be reclassified as Gasoil after blending with the latter in order to meet its winter diesel specification. A negative entry for one product must be compensated by a positive entry (or several entries) for one or several products and vice versa. The total net effect should be zero.

Please note that Interproduct Transfers for Other products includes interproduct transfers of crude oil and NGL. Please refer to Table 4.1 on page 51

#### 4.14 Demand

**Deliveries or sales to the inland market (domestic consumption), plus refinery fuel, plus international marine and aviation bunkers, plus direct use of crude oil and NGL**

The total demand of oil in a country includes the volume of oil required, on the one hand to supply all final consumers, energy transformation units (including refineries), energy producers within the country and on the other hand to provide all the national and foreign customers with fuels which they will use in international navigation and aviation (e.g. international aviation, marine bunkers, fishing etc.).

Total oil demand also includes volumes of crude oil, NGL and other hydrocarbons which are used directly without being processed in petroleum refineries (direct use). It concerns mainly oil which can be used unprocessed by power plants to generate electricity and heat.

Since in most oil balances the information for some of these flows is available the equation looks as follows (see Fig 4.3 on page 53):

Please note that non-energy consumption should be included.

Figure 4.3: Demand flows

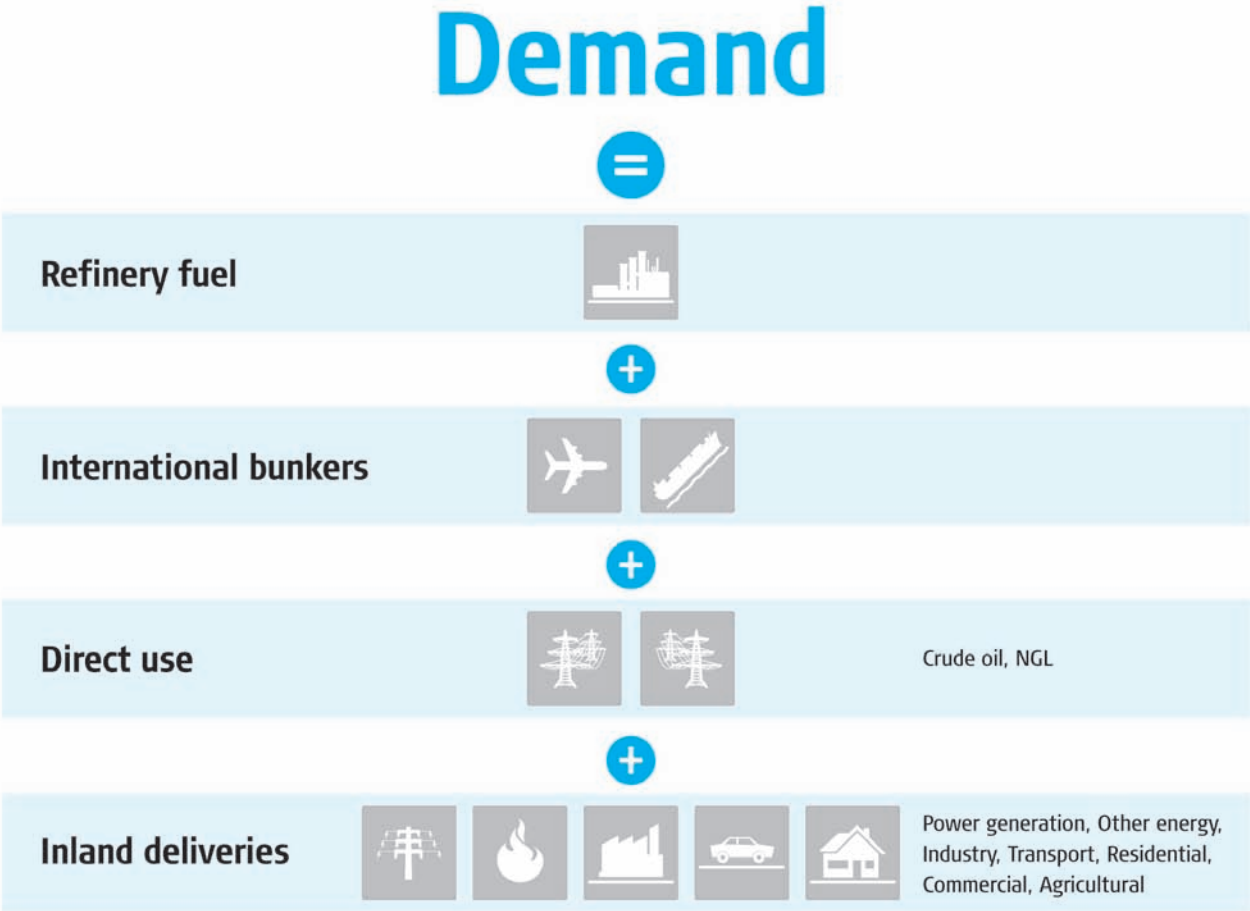



# Chapter 5: Verification of data quality

---

## 5.1 Data quality assessment

Data quality encompasses many aspects. For the data submitted in the JODI Oil questionnaire, the following items have been taken into account when assessing a country's data quality:

- **Timeliness:** The JODI Oil database is expected to be updated regularly. Timeliness indicates whether submissions were received by the expected deadline. Ratings over a six month period ranging from "good" to "less timely" are given according to the number of submissions received within the deadline.
- **Sustainability (of submission):** Sustainability refers to the number of the JODI Oil submissions received within a given period. For example if a country over a six month period has submitted all six questionnaires, then it is given a "good" rating; if fewer questionnaires were submitted then lower ratings are assigned.
- **Completeness:** Completeness measures the number of expected data points out of the maximum in the JODI Oil questionnaire received by the expected deadline. A "good" rating is given when more than 90% of the data are provided for production, stock changes, closing stock levels and demand.
- **Accuracy:** Accuracy of JODI Oil data for a country is much more difficult to measure, as there is often no real benchmark to measure against. Moreover, if data are accurate for one flow, e.g. production, it does not necessarily mean that all the other flows are accurately reported. It is thus almost impossible to give a single rating concerning the data accuracy of an individual country.

To be able to establish some indication of data accuracy however, several verification methods can be used for evaluation of data, either by international organisations or by national administrations providing the data. The next chapter will be dealing with the type of measures national administrations can take to ensure data accuracy.

For more information and the latest update of JODI countries' data quality, please consult the website: [www.jodidata.org](http://www.jodidata.org)

## 5.2 Focus on data accuracy

Accuracy is an essential characteristic of an ideal database. With it, users can be assured of the database's reliability and usability, which are paramount to statistical analysis.

As JODI Oil was initiated in order to measure how quickly national administrations could provide accurate data on a monthly basis, timeliness and completeness became the focus of attention during the first years of the Initiative. However, now that a database is in place where information is stored, it is essential that accuracy be given the necessary attention that it deserves.

Initially the six participating organisations and the IEF had taken a decision that the database would only be released if it was proven to be of sufficient quality. An extended evaluation exercise was carried out during 2005; the results of which showed that quality - although not perfect - was satisfactory, especially for the top 30 producers and consumers. It was therefore decided in November 2005 to open up the database to the public. In anticipation of criticism from some users, colour coding was added to indicate data confidence (See Chapter 8).



Now that the database is operational, it is imperative that accuracy continues to improve. Accuracy must to be evaluated by both the international organisations to which countries submit their data and by the national administration submitting the data. International organisations each have their respective techniques to verify data accuracy and they do so on a regular basis, contacting national administrations in case of problems.

In order to facilitate the task of data accuracy evaluation by national administrations, this chapter provides a set of instructions and possible checks for verification of data accuracy from the standpoint of the national statisticians.

Some data accuracy verification techniques that can be applied to JODI Oil submissions are as follows:

1. Balance Check
2. Internal Consistency Check
  - 2.1 Fuel Balance: Sum of Products versus Total Oil
  - 2.2 Stocks Check
3. Time Series Check
4. Visual Check

Please note that some of these checks only provide an indication of accuracy. It is important to use a combination of checks in order to obtain the best results.

### 5.2.1 Balance check

#### Primary oil

$$\text{Calculated Refinery Intake} = \text{production} + \text{From Other Sources} + \text{Imports} - \text{Exports} + \text{Products transferred/Backflows} - \text{Direct use} - \text{Stock change}$$

#### Oil products

$$\text{Demand} = \text{Refinery output} + \text{Receipts} + \text{Imports} - \text{Exports} - \text{Products transferred} + \text{Interproduct transfers} - \text{Stock change}$$

This is the simplest form of accuracy check. Herein, the statistician should check that the calculated supply is not very different to the reported demand. The calculated Refinery intake/Demand is expressed in the above formulas.

The Calculated Refinery Intake/Demand using the above formula should not be very different from the reported Refinery Intake/Demand. The difference is automatically calculated in the row Statistical difference in the JODI Oil questionnaire. Ideally, the deviation should be between -5.0 and 5.0%. If the deviation is outside this range, the statistician should review the data for all the flows and make corrections where necessary. However, if after due verification, the deviation is still large, the data may be submitted to the respective organisations. If more accurate data are received in the following month then a revised and corrected balance should be resubmitted the following month.

This data check is applicable only if data for the flows are complete and reliable. Moreover sometimes the deviation between calculated supply and the other flows is for some valid reason larger than -5% and +5%. This balance check can therefore only be considered as one of the possible checks which can be carried out to evaluate accuracy.

Table 5.1 illustrates an example where reported refinery intake is more than 5% lower than Calculated Refinery Intake. There are several possible reasons for this. The statistician may suspect that the Refinery Intake and Demand may be underreported. But it would also be possible that the other flows are over-reported. Therefore it is suggested that all of the data be reviewed for accuracy.

**Table 5.1: Example 1 of internal balance check**

Unit: 1,000 metric tons

		Crude oil
+	Production	2
+	From Other Sources	
+	Imports	3681
-	Exports	0
+	Products transferred / Backflows	
-	Direct use	200
-	Stock change	-295
-	Statistical difference	228
=	Refinery intake	3550
%	Percentage statistical difference	6.4%

### Internal consistency -check

#### 5.2.1.1 Oil products balance: sum of products versus total oil products

$$\text{Total oil products} = \text{LPG} + \text{Naphtha} + \text{Motor/aviation gasolines} + \text{Kerosenes} + \text{Gas/diesel oil} + \text{Fuel oil} + \text{Other oil products}$$

Another measure of accuracy is consistency. The category Total oil products should be equal to the sum of the reported products namely: LPG, Naphtha, Motor/aviation gasoline, Kerosenes, Gas/diesel oil, Fuel oil and Other oil products including refinery gas, ethane, naphtha, petroleum coke, white spirit & SBP, paraffin waxes, lubricants and other products. (See Chapter 3).

The statistician should ensure that this property holds. Should this not be the case, then a careful review and appropriate corrections of the data are necessary before submitting the data to their respective organisations. Automatic checks are incorporated in the questionnaire to point out when the total is not equal to the sum of the parts.

**Table 5.2: Example 1 of fuel balance check**

Unit: 1,000 metric tons

	LPG	Naphtha	Motor/aviation gasoline	Kerosenes	*Of which Kerosene type jet fuel	Gas/diesel oil	Fuel oil	Other oil products	Total oil products (5)+(6)+(7)+(8)+(10)+(11)+(12)
	(5)	(6)	(7)	(8)	(9)	(10)	(11)	(12)	(13)
Refinery output	126	160	866	334	331	1083	942	994	2338
Receipts									
Imports	59						60	2	121
Exports	13	160	208	143	140	555	26	117	1222
Products transferred									
Interproduct transfers						55	-55		0
Stock change	-2		-47	-10	-10	101	-92	-40	-90
Statistical difference	-2	0	5	0	0	0	0	0	-2164
Demand	176		700	201	201	482	1013	919	3491
Closing stocks	95		884	317	317	1065	1154	511	4026

\*Of which: Kerosene type jet fuel should not be counted in the Total oil products.

In Table 5.2, the column Total oil products is the sum of all the products, namely: LPG, Naphtha, Motor/aviation gasoline, Kerosenes, Gas/diesel oil, Fuel oil and Other products. The Total oil products for five out of the eight flows are equal to sum of LPG, Naphtha, Motor/aviation gasoline, Kerosenes, Gas/diesel oil, Fuel oil and Other products which shows that these flows are internally consistent. However, the sum of all products for Refinery output is larger than the corresponding Total oil products. As a result there is a considerable statistical difference observed. Therefore, there is an error in the data for that particular flow. This method does not apply to stock changes.

**Table 5.3: Example 2 of fuel balance check**

Unit: 1,000 metric tons

	LPG	Naphtha	Motor/aviation gasoline	Kerosenes	*Of which Kerosene type jet fuel	Gas/diesel oil	Fuel oil	Other oil products	Total oil products (5)+(6)+(7)+(8)+(10)+(11)+(12)
	(5)	(6)	(7)	(8)	(9)	(10)	(11)	(12)	(13)
Refinery output	126	160	866	334	331	1083	942	994	4505
Receipts									
Imports	59						60	2	1021
Exports	13	160	208	143	140	555	26	117	1222
Products transferred									
Interproduct transfers						55	-55		0
Stock change	-2		-47	-10	-10	101	-92	-40	-90
Statistical difference	-2	0	5	0	0	0	0	0	903
Demand	176		700	201	201	482	1013	919	3491
Closing stocks	95		884	317	317	1065	1154	511	4026

\*Of which: Kerosene type jet fuel should not be counted in the Total oil products.

From the previous table, the sum of Imports for individual products is lower than Total oil products Imports. This suggests that the Imports data of Total oil products is misreported or there are missing Imports data for some products. As the statistical difference is very high, it is likely that the Imports of Total oil products is misreported.

Hence there is a need for statisticians to check the values of all the products including Total oil products.

### 5.2.1.2 Stocks check

$$\text{Stock change} = \text{Closing stock for M-1} - \text{Closing stock for M-2}$$

The difference between the Closing stock of the latest month (**M-1**) and the Closing stock of the previous month (**M-2**) should be equal to the reported Stock change of the latest month. If for any reason this is not the case, the statistician should investigate and make the necessary correction. The difference between the reported stock change and calculated Stock change should be 0. A reason for a deviation could stem from the Stock change for **M-1** being obtained using preliminary Closing stock for **M-2**. If **M-2** stock levels have since been revised, then a revision for the previous months should be submitted.

However, if this is not the case despite serious efforts to achieve a balance, the statistician could settle to a maximum deviation of not greater than 5.0%.

**Table 5.4: Example of checking consistency of stocks data**

	Crude oil	LPG	Motor/aviation gasoline	Kerosenes	Gas/Diesel Oil	Fuel oil	Total oil products
<b>Closing stock level</b>							
M-1 (Jan)	1637	181	660	259	533	214	2685
M-2 (Dec)	1618	192	778	213	676	260	2880
<b>Stock change in M-1 (Jan)</b>	19	-18	-118	54	-143	-48	-195
<b>Calculated stock change</b> (M-1 – M-2 or Jan – Dec)	19	-11	-118	46	-143	-46	-195
<b>Difference</b> (Calculated – Reported)	0	-7	0	8	0	-2	0
<b>Percentage difference</b> (Difference/Stock change)	0%	39%	0%	15%	0%	4%	0%

In Table 5.4, the calculated Stock change is computed using the above-mentioned formula. This calculated Stock change should be equal to the reported Stock change. In the above example, the reported Stock change for LPG, Kerosenes and Fuel Oil are not equal to the calculated Stock change.

When calculating the percentage difference it is noticeable that for LPG and Kerosenes the differences are larger than 5%, whereas for Fuel oil the difference is only 4%. Therefore the stock data for LPG and Kerosenes need investigation, while the fuel oil data seems within reasonable error limits.

### 5.2.2 Time series check

$$\text{Percentage change (\%)} = \frac{\text{Current month data} - \text{Previous month data}}{\text{Previous month data}} \times 100$$

This is another method that the statistician could use to check the accuracy of some of the flows, for example Production, Refinery output, Closing stocks or Demand. The method is less useful for trade and stock changes. A time series check involves comparing the demand data of the latest month to that of the previous month and/or to the data of the same month in the previous year.

The underlying reason for checking monthly data with previous data is that the percentage change, in for example demand, is usually limited from one month to the next. The statistician should compute the monthly growth rates and use the past growth rates as an indication of the trend of the growth rate for the latest month. If Demand in the previous seven months has been growing at 3%, then it is likely to expect a similar growth this month. However this can only be considered as an indication, as many times there are logical reasons for larger than expected deviations.

In countries where there is a large seasonal pattern in Demand, a comparison with the same amount of the previous year is more relevant.

Should the growth rate therefore exceed or go below the trend, the statistician should investigate. If the percentage change seems correct, then it is recommended that the statistician find the cause of such occurrence. If the reason is plausible, then the data might be accurate despite not going with the trend.

**Table 5.5: Comparing growth rate for the latest month to the historical trend**

	Monthly Growth Rate (Previous 12 months)			March
	Minimum	Maximum	Average	
LPG	-9.2%	11.1%	0.8%	15.0%
Motor/aviation gasoline	-10.1%	8.9%	0.0%	8.0%
Kerosenes	-10.3%	8.1%	0.5%	-10.4%
Gas/diesel oil	-12.0%	9.4%	-0.6%	-3.0%
Fuel oil	-25.3%	23.0%	1.0%	5.0%
Total oil products	-7.1%	7.3%	-0.5%	2.0%

In Table 5.5, the calculated growth rates for the demand in March using the above formula are compared with the maximum and minimum monthly growth rates during the previous 12 months or year. The growth rates of LPG and Kerosenes for the month of March are higher than the maximum growth rates and lower than the minimum monthly growth rates observed in the previous 12-month period, respectively.

There is no certainty that such developments could not happen in the oil market, for example an exceptionally cold winter may make the Demand for Kerosenes much higher than the previous year, or adversely an exceptionally mild winter may result in much lower demand. However, seeing growth rates which are much higher or lower than those seen in the last 12 months may provide an indication that data should be investigated.

### 5.2.3 Refinery intake/output check

This check is carried out to verify the consistency of the refinery data by comparing refinery intake and refinery output.

To check consistency of refinery operation each month, the ratio of the Refinery output of Total oil products and the Refinery intake of all primary products (Crude oil, NGL, Other) should be calculated. This ratio is also called refinery yield. This check can be conducted in either mass (ton) or volume (bbl, litre) units although there are different characteristics between mass and volumetric comparisons that should be taken into account.

$$\text{Refinery Yield (\%)} = \frac{\text{Refinery output of Total oil products}}{\text{Refinery intake of Total primary products}} \times 100$$

In a normal refinery process, losses occur during the distillation processes due to evaporation. Refinery losses are the amount by which the refinery output is smaller than the input (i.e. refinery yield <100%).

Refinery/processing gains may occur if the total refinery output exceeds the refinery intake (refinery yield > 100%) when the amount is measured in volume.

Therefore, depending on whether the data are expressed in mass or volume units, the ratio should be evaluated differently:

- In case of comparing figures in mass units (tons), the yield should be smaller than but close to 100%. In principle no gains should occur. Figure 5.1 shows a suggested way of comparison.

**Figure 5.1 Refinery intake v.s. refinery output comparison in ktons**

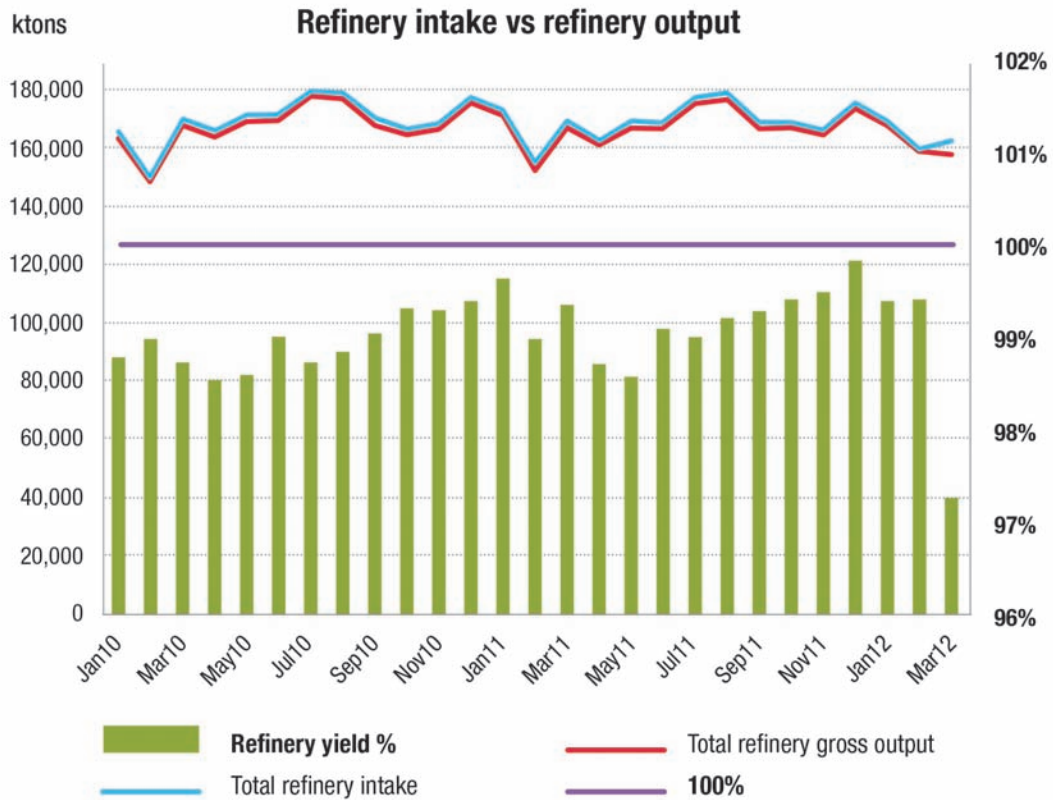

- If the data are measured in volumetric units (bbls, litres) either gains or losses are possible. Refinery gains can occur due to the fact that the output (processed oil products) in total takes a higher volume (lower specific gravity) than the input (crude oil and feedstocks). See Figure 5.2.

**Figure 5.2 Refinery intake v.s. refinery output comparison in kbbls**

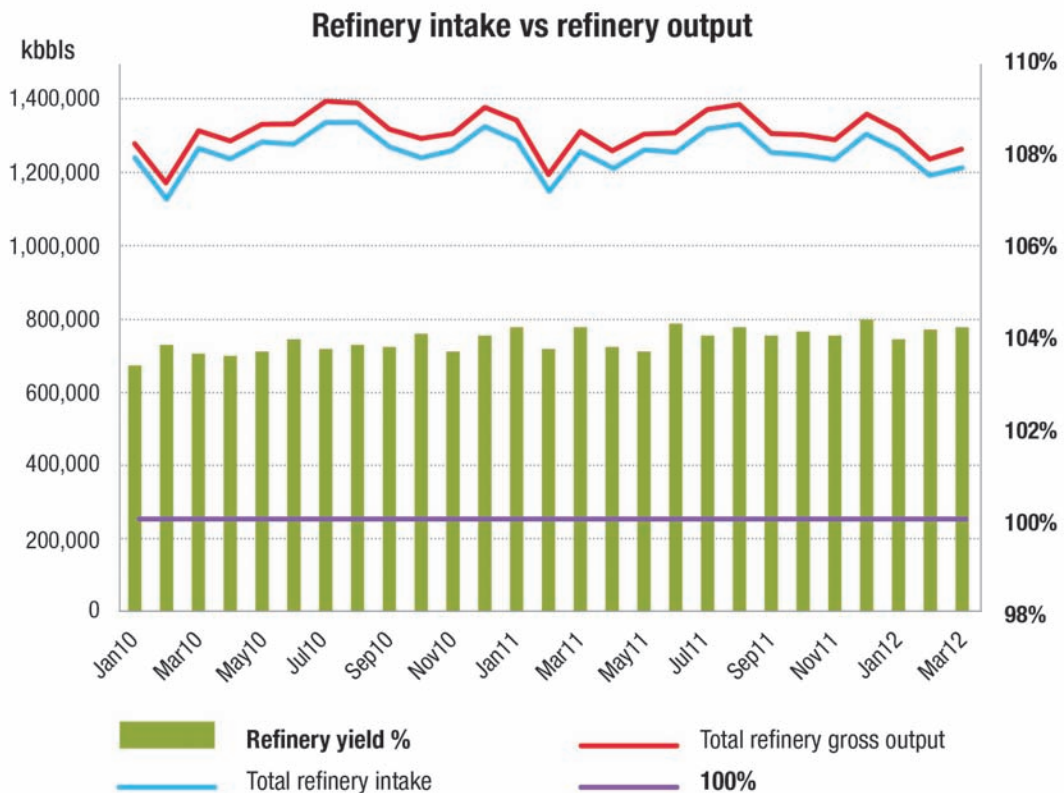

The refinery yield of a country is usually consistent over time. A graph similar to the ones above using historical data enables one to check the consistency of refinery operations over time. Any data outlier should be investigated.

## 5.2.4 Visual checks

An easy method to rapidly verify time series is to graphically represent the data series. By using this method, outliers, which are data points far from the rest of the data, can be easily detected. To be able to graphically show time series however, it is essential that the statistician has developed and maintained a database of historical data.

The method for visually checking time series can be used for most of the flows, although it is less easy to spot outlying data for stock changes, as these are fluctuating between positive and negative and can vary more than the other data.

An example of refinery intake data is shown below where two values are clearly out of the normal range. The low value of refinery intake (April 2005) could indeed be valid, as refineries might have closed down for refinery maintenance, however the high value in December 2005 seems out of line, as it is unlikely that refinery intake can have increased substantially for one month.

If such occurrences are visible, the statistician should investigate further to determine whether the value is valid or not.

**Figure 5.3 Refinery intake volumes**

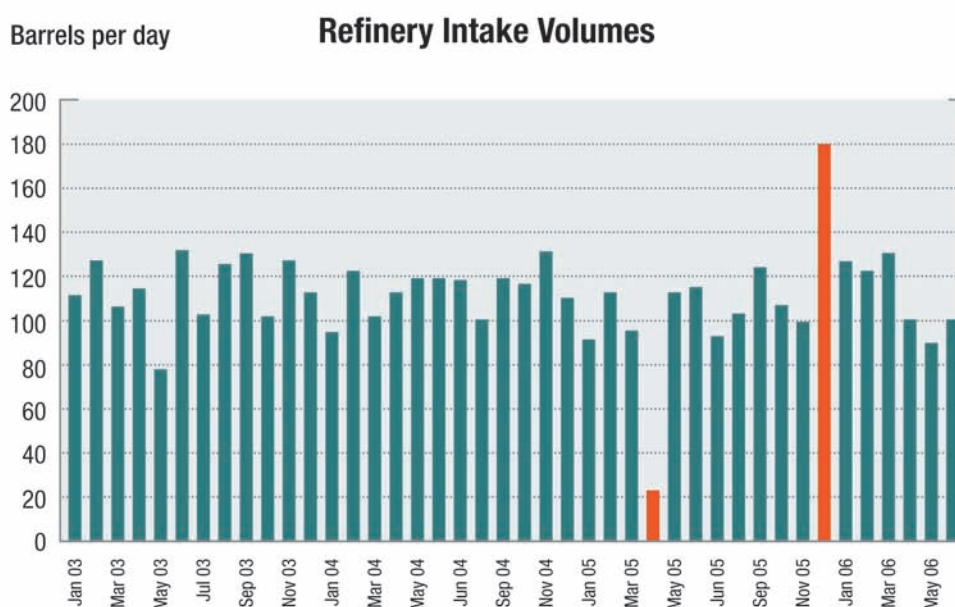

## 5.3 Monthly versus annual data

### 5.3.1 Monthly data

#### 5.3.1.1 Data collection and coverage

Production and stock data are collected from oil companies every month.

Challenges/problems:

- Reporting period is short.
- Not all the data providers are able to send the data to the national administration in charge of JODI Oil.

Trade data (Exports/Imports) is collected mainly from the customs offices.

Challenges/problems:

- Longer time lag for getting the trade data (in many developing countries).
- Consolidation of value and physical data.

Trade data, when they become available, can be considered as complete coverage.

### 5.3.1.2 Estimates or full coverage data

When monthly data collection from data providers is incomplete, the national administration may estimate the missing data and use its monitoring system to check the consistency of the estimates over months. Meanwhile, the national administration needs to improve sustainable data submission from all the data providers through explaining benefit of their participation in the data gathering at a national level.

The estimation and consistency check methodologies should be clearly stated in country notes (metadata).

### 5.3.1.3 Missing monthly data

The national administration in charge of JODI Oil is not sending data to the JODI Oil Organisation(s) to which the country is a member.

Problem:

- JODI organisations do not estimate data that has not been submitted by participating countries nor change data submitted by them as the data is officially sanctioned. Therefore, the missing data point will appear as empty cells in the JODI Oil World Database.
- The missing data is negatively affecting the comparability and completeness of the JODI Oil World Database, jeopardising the reliability of the database.

## 5.3.2 Annual data

Annual data is, in principle, a simple aggregation of the twelve consecutive months. However, given the coverage described above there could be the following cases observed:

### 5.3.2.1 Annual data is a simple sum of the 12 consecutive months of the year

The national administration in charge of JODI Oil collected the necessary data from all the data providers and data was not revised over the 12 month period. In this case, the annual data is the sum of the 12 months' data registered in the JODI Oil World Database.

### 5.3.2.2 Monthly data is to be re-consolidated in order to derive annual data from the monthly data

If national administration in charge of JODI Oil made estimations for some of the months due to incomplete coverage, a consolidation of data is required. The consolidation needs to assure the coverage and reliability of data. Also, the monthly data should be adjusted to assure the consistency between monthly and annual data.

The estimation and consolidation methodologies should be clearly stated in country notes (metadata).

## 5.4 Common reporting errors

Another way to improve data accuracy is by preventing common errors in data collection, processing and reporting. To ensure that these errors are avoided, a table is provided showing the most frequent "common errors" and a corresponding suggestion on how to avoid them. If such errors are unavoidable due to definitional differences, it has to be indicated in country notes (metadata).



Products and Flows	Common Errors	Suggested Preventive Measures
<b>Crude oil Production</b>	<ol style="list-style-type: none"> <li>In some cases, the data exclude lease condensates.</li> <li>In some cases, wellhead production instead of marketable data are reported.</li> <li>Crude oil production of foreign companies operating within the country are reported as imports.</li> </ol>	<ol style="list-style-type: none"> <li>Ask data providers to report Crude oil, lease condensate and NGL separately, if the data are available, so that the statistician can follow the JODI Oil definition.</li> <li>Statisticians should ask upstream oil companies to report the marketable production.</li> <li>Crude oil production <b>within the national boundaries of the country</b> is indigenous production of that country, no matter the nationality of the producer.</li> </ol>
<b>Refinery intake</b>	Like in Crude oil Production, refinery intake includes NGL and refinery feedstocks or excludes lease condensate.	Ask data providers to report Crude oil, lease condensate and NGL separately, if the data are available, so that the statistician can follow the JODI Oil definition.
<b>Refinery output</b>	<ol style="list-style-type: none"> <li>In some cases, LPG output from gas separation plants are reported as refinery output.</li> <li>In some cases, there is double counting of finished products produced from intermediate products.</li> </ol>	<ol style="list-style-type: none"> <li>Report only the output of oil refineries.</li> <li>Only production of finished oil products should be reported in refinery output. If some products are used for further processing to other products, then only the final output should be reported to avoid double counting. An example is naphtha re-processed to produce other products. The re-processed naphtha should not be included as refinery output. Only the amount exported or delivered to final consumers should be reported.</li> </ol>
<b>Demand</b>	<ol style="list-style-type: none"> <li>In some cases, refinery fuel and aviation/marine bunkers are not included.</li> <li>In some cases, only inland sales are reported. Refinery fuel and direct use of Crude oil are not included in Total oil products.</li> <li>In some cases LPG from gas separation plants are not included.</li> <li>The demand of Motor and Aviation gasoline includes the direct use of pure biogasoline. (This also applies to some other fuels)</li> </ol>	<ol style="list-style-type: none"> <li>Demand data should include refinery fuel and aviation/marine Bunkers and direct use of Crude oil.</li> <li>Demand data should include refinery fuel and aviation/marine bunkers and direct use of Crude oil.</li> <li>Practically, it is difficult to trace the source of LPG. All LPG sold should be reported.</li> <li>The direct use of pure biogasoline should be excluded from demand. Demand should only include the use of Motor and Aviation gasoline as well as the gasoline blended with biogasoline, but not the direct use of pure biogasoline itself. (This also applies to some other fuels)</li> </ol>

Products and Flows	Common Errors	Suggested Preventive Measures
<b>Closing stock</b>	<ol style="list-style-type: none"> <li>In some cases, only industry or government stocks are included in the total and not the sum of both.</li> <li>Some countries do not report stocks data due to confidentiality.</li> </ol>	<ol style="list-style-type: none"> <li>By definition, the total national territory stocks should be the sum of government and industry stocks.</li> <li>Data providers should be informed that individual stocks information will not be divulged. The national administration will only release the total stocks data.</li> </ol>
<b>Stock change</b>	<ol style="list-style-type: none"> <li>In some cases, a stock build is submitted with a negative sign while a stock draw is shown with a positive sign.</li> <li>In some cases, stock change is estimated as the difference between supply and demand.</li> <li>The difference in closing stock level of M-1 and M-2 is not equal to the reported stock change.</li> </ol>	<ol style="list-style-type: none"> <li>Stock change should be calculated as the difference between closing stocks – opening stocks, or of closing stocks (M-1) – closing (M-2) stocks.</li> <li>National administrations should collect data for both the closing stock levels and the stock changes.</li> <li>This may be true in some cases due to statistical discrepancy. In this regard, this difference should not be bigger than 5% or less than -5%.</li> </ol>
<b>Motor/ aviation gasoline</b>	<ol style="list-style-type: none"> <li>In some cases, aviation gasoline and blending components are not included in the Motor/aviation gasoline data submitted.</li> <li>In some cases, alcohol production is included in the reported Motor/ aviation gasoline production.</li> <li>In some cases, amount of pure biofuels used directly in engines is included in the reported Motor/ aviation gasoline.</li> </ol>	<ol style="list-style-type: none"> <li>Please strictly follow JODI Oil definition.</li> <li>Only Motor/aviation gasoline production, with or without alcohol blend, should be reported. The amount of alcohol production, especially if it is not blended with gasoline, should not be included.</li> <li>The amount of pure biofuels used directly in engines should not be included under Motor/aviation gasoline.</li> </ol>
<b>Kerosenes</b>	<ol style="list-style-type: none"> <li>In some cases, the Kerosenes data submitted do not include Kerosene type jet fuel.</li> <li>In some cases, other kerosene is included in Gas/diesel oil.</li> <li>In some cases, amount of pure biofuels used directly in engines is included in the reported Kerosenes.</li> </ol>	<ol style="list-style-type: none"> <li>The JODI Oil definition for Kerosenes includes Kerosene type jet fuel and other kerosene.</li> <li>The JODI Oil definition includes other kerosene under Kerosene and not in Gas/diesel oil.</li> <li>The amount of pure biofuels used directly in engines should not be included under Kerosenes.</li> </ol>



# Chapter 6: Estimations and revisions of data

---

## 6.1 Estimations

It is preferable that all JODI Oil data are submitted with real data, without any estimation. However, it is also possible that due to the size of certain flows and certain products, the data are either not collected on a regular basis, or they may exceptionally be missing for a certain time period.

The JODI data are submitted by the national authority of the participating country. These data are considered authoritative and are not subject to alteration by any of the JODI partner organisations. The estimation methodologies presented below are only a guideline to assist national administrations responsible for filling the JODI Oil questionnaire.

### 6.1.1 Data are not collected

Estimates should only be used for flows and products which represent a small proportion in the oil balance, and which have the value of completing the major oil flows.

For example if your country is a small exporter of LPG and this represents less than 10% of total exports on an annual basis, then it is feasible to include a monthly estimate for this flow and product in the JODI Oil data. However it is essential that the estimates are benchmarked periodically. This can be done by comparing monthly data to annual data or by comparing monthly data with information which becomes available with some time delay.

**Please note that it is good practice to indicate which data have been estimated.**

#### How to estimate?

- Establish the importance of the flow and product to be estimated
- Work out if this flow/product is correlated with another flow for which you have data e.g. LPG exports are probably strongly correlated to either refinery production or NGL production
- Investigate if there is a seasonal trend for the flow/product
- Regular verification is essential

An example:

Country Z does not collect data for Total oil products, but has all the information for all flows for the products specified in the JODI Oil. How can Total oil products be derived?

It is important to establish the size of the Other oil products in the oil balance. This can be determined by looking at a full balance of annual or quarterly data. The sum of the five petroleum products is lower than the Total oil products total, as "Other oil products" are consumed in the country (e.g. lubricants, paraffin waxes, etc.).

Below is the annual oil balance of Country Z (Table 6.1). The last four columns show on the one hand the sub-total of the six major products and their percentage share in the Total oil products, and on the other hand the size and percentage of the Other oil products.

**Table 6.1: Annual balance for country Z**

Unit: 1,000 metric tons

Annual balance	LPG	Naphtha	Motor/ aviation gasoline	Kerosenes	Gas/diesel oil	Fuel oil	Total oil products
Refinery output	1050	2585	10152	6680	23457	9019	53790
Receipts	0	0	0	0	0	0	511
Imports	1024	640	753	1328	13217	4163	22539
Exports	228	162	2866	120	822	1461	5770
Products transferred	0	0	0	0	0	0	10
Interproduct transfers	0	-102	102	0	0	511	0
Stock change	0	-6	-9	79	875	-71	885
Statistical difference	-22	12	180	426	627	420	1627
Demand	1859	2955	7970	7383	34350	11883	68548
<i>Closing Level</i>	<i>309</i>	<i>530</i>	<i>1504</i>	<i>738</i>	<i>5570</i>	<i>1608</i>	<i>10608</i>

Annual balance	Subtotal six products	% of Total	Other oil products	% of Total
Refinery output	52943	98.4%	847	1.6%
Receipts	0	0.0%	511	100.00%
Imports	21125	93.7%	1414	6.3%
Exports	5659	98.1%	111	1.9%
Products transferred	0	0.0%	10	10.0%
Interproduct transfers	511		-511	
Stock change	877		8	
Statistical difference	1643		-16	
Demand	66400	96.9%	2148	3.1%
<i>Closing Level</i>	<i>10259</i>	<i>96.7%</i>	<i>349</i>	<i>3.3%</i>

From the above table, it can be derived that on an annual basis, the six major products account for 98.4% of refinery output and for 96.9% of Demand.

Meanwhile the Other oil products account for 1.6% of refinery output and for 3.1% of demand. Given that the Other oil products category accounts for less than 10% in all flows, an estimate can be derived on a monthly basis in order to provide the total for Total oil products.

## How to derive a monthly estimate?

Below is Country Z's submission for July 2012. There is no data for the Other products Demand, which will be estimated using Table 6.1.

**Table 6.2: Monthly JODI Oil data for country Z**

Unit: 1,000 metric tons

Monthly balance	LPG	Naphtha	Motor/ aviation gasoline	Kerosenes	Gas/diesel oil	Fuel oil	Total oil products
Refinery output	88	211	846	557	1955	752	4483
Receipts	0	0	0	0	0	0	60
Imports	85	82	63	111	1101	348	1878
Exports	19	15	239	10	69	125	481
Products transferred	0	0	0	0	0	0	2
Interproduct transfers	0	-5	5	0	0	60	0
Stock change	5	6	-12	7	73	-15	54
Statistical difference	-6	2	23	35	52	60	?
Demand	155	265	664	615	2863	990	?
<i>Closing Level</i>	26	44	125	62	464	134	884

Monthly balance	Subtotal six products	% of Total	Other oil products	% of Total
Refinery output	4408	98.3%	75	1.7%
Receipts	0	0.0%	60	100.0%
Imports	1790	95.3%	88	4.7%
Exports	476	99.0%	5	1.0%
Products transferred	0	0.0%	2	100.0%
Interproduct transfers	60		-60	
Stock change	64		-10	
Statistical difference	167		?	
Demand	5552	96.9%	?	3.1%
<i>Closing Level</i>	855	96.7%	29	3.3%

If the monthly demand of the six major products (sub-total) is 5552 thousand metric tons, then the Total oil products can be calculated using the percentage we derived from the annual balance.

We have determined that on a yearly basis the six major products account for 96.9% of demand in the country, therefore we can estimate Total oil products Demand for this month as:  $5552/0.969= 5730$ . (i.e. Subtotal six products / % of Total).

The missing Other oil products account for  $5730 - 5552 = 178$  thousand tons.

It is essential however to establish that for none of the flows of the Other oil products there is a strong seasonal trend; should there be, then the seasonality of the product needs to be taken into account when making the estimate.

## 6.1.2 Data are exceptionally not available

Although data may be collected on a regular basis, in some time periods it is possible that a company does not report its data either on a timely basis, or for other reasons such as computer problems, staff changeover, etc. Unfortunately these occurrences happen in reality more often than hoped for and result in complications for the statistician.

### How to estimate?

- Determine the different flows and products which the missing company usually reports
- Work out the average market share of the company compared with that of other companies for each flow and product
- Estimate the company's data on the basis of the other companies
- Alternatively, if the company's share has not been moving very much in the last year, use the same data reported for the corresponding month of the previous year
- In case there is no strong seasonality, and there is only one month missing, the previous month's data could also be used
- Use the trend of the total market as a measure to derive the company's data.

An example:

Country Z collects data from three different companies (A, B and C). Company B is late in providing its data for the month of November, but all the other companies have provided their data. The data for example for gas/diesel oil is missing; in order to obtain some estimate there are various alternatives:

- the average share of the company in the total can be determined and used – see below

**Table 6.3: Refinery output of Gas/diesel oil of country Z**

Gas/Diesel Oil				Unit 1,000 Metric Tons
	Sept-12	Oct-12	Nov-12	Average Company Share
<b>Refinery Output</b>	2400	2750	?	
<i>Company A</i>	720	880	775	31%
<i>Company B</i>	480	481	?	19%
<i>Company C</i>	1200	1389	1300	50%

To derive Company B's output, the shares of Companies A and C are used. The output of Companies A and C in Nov-12 is 2075 thousand tonnes, and this accounts for 81% (see Table 6.4) based on September and October data. Therefore the estimated total is  $2075/0.81=2562$  and Company B's output can be calculated as  $2562-2075=487$  thousand tonnes.

**Table 6.4: How to estimate missing data - example 1**

Gas/Diesel Oil				Unit 1,000 Metric Tons
	Sept-12	Oct-12	Nov-12	Average Company Share
<b>Refinery Output</b>	2400	2750	<b>2562e</b>	
<i>Company A</i>	720	880	775	31%
<i>Company B</i>	480	481	<b>487e</b>	19%
<i>Company C</i>	1200	1389	1300	50%
<b>Total A+C</b>			2075	81%

- The same data as previous month or as same month previous year.

If the previous month's data is used, then the underlying assumption is that there is no strong seasonality between the two months, and that there is no major change in the company's output (e.g. there is no refinery maintenance plan in November 2012). See Example 1 in Table 6.4.

If seasonality is to be taken into account, then it is probably better to use the same month previous year's data (See Example 2 in Table 6.5). However, this means that other assumptions are made: that the company over the year has not increased or extended its refinery.

**Table 6.5: How to estimate missing data – example 2**

Gas/Diesel Oil		Unit 1,000 Metric Tons				
	Nov-12	Sep-12	Oct-12	Example 1 Nov-12	Example 2 Nov-12	
<b>Refinery Output</b>	2600	2400	2750	<b>2556e</b>	<b>2525e</b>	
<i>Company A</i>	900	720	880	775	775	
<i>Company B</i>	450	480	481	<b>481e</b>	<b>450e</b>	
<i>Company C</i>	1250	1200	1389	1300	1300	

So in these examples above, different results are obtained, depending on the underlying assumptions. The **quality of the estimates is of course only as good as the underlying assumptions are**. In the above tables, where total refinery output varies between 2525 and 2562, the difference in the total refinery output for gas/diesel oil only differs by 1.5%, which is much below the 5% error used as an acceptable standard in the JODI Oil quality evaluation.

- A fourth possibility is to derive the company's data using the total trend.

To apply this measure it is necessary to assess whether the missing company in the past has followed the market trend. If over the past six months there is a very strong correlation between Company B's refinery output and the total refinery output, then the trend can be applied to company B's output.

**Table 6.6: How to estimate missing data – example 3**

Gas/Diesel Oil		Unit 1,000 Metric Tons						
	Nov-11	May-12	Jun-12	Jul-12	Aug-12	Sep-12	Oct-12	Nov-12
<b>Refinery Output</b>	2670	2600	2585	2500	2520	2425	2750	<b>2794</b>
<i>Company A</i>	860	900	885	875	865	800	880	900
<i>Company B</i>	450	450	450	425	430	425	481	<b>472</b>
<i>Company C</i>	1360	1250	1250	1200	1225	1200	1389	1422
<b>% change versus previous year</b>								
<i>Company A+C</i>	-5.3%	-5.0%	-3.0%	2.5%	4.7%	5.2%	4.5%	4.8%
<i>Company B</i>	-4.7%	-4.6%	-4.0%	4.5%	5.0%	5.4%	4.0%	<b>?</b>

Company B's output here is estimated using the market trend, and applying a 4.8% growth rate to the November 2011 data. The result is  $450 \times 1.048 = 472$ .

The same method can be applied to other flows, e.g. production, demand and stock level data, but is less useful for trade, as the variability from month to month is much higher.

It has to be borne in mind that the above methods could not be used when the company's missing data has an overriding market share or dominates the market.



## 6.2 Revisions

Monthly data are very frequently revised, for many reasons, some of which may be that the companies work with provisional data and they may provide final data later in the year, or they may have discovered mistakes, and corrected them. Moreover it is possible that there are new companies entering the market, which were not taken into account in first submissions.

The JODI Oil questionnaire requests for data to be submitted for M-1 (last month) and M-2 (month before last). There is therefore already a possibility to revise data provided in the questionnaire. This however should not prevent countries/economies to submit revisions to monthly data for much earlier time periods.

Please note that when sending revisions for one month, this impacts the stock level data for the previous month (M-2). For example, when stock level and changes are revised for September 2011, then it is very possible that the closing level for August 2011 was also revised, necessitating a submission for that month as well.

The JODI Oil World Database aims to have monthly data as accurate as possible starting from January 2002. The database is a live database and is updated monthly with the latest monthly submissions including also all the revisions member countries may have submitted.

# Chapter 7: Examples of practices –

## A few examples of JODI Oil data collection and methodology in member countries

---

The six international organisations asked some of their member countries to provide their monthly oil data collection practices and to highlight their experience in dealing with bottlenecks and weaknesses in the data supply chain. Although it is recognised that each country may have unique and evolving data collection practices, it is still considered that some general guidance may be useful to other countries.

An understanding of the history behind the establishment of new data collection systems or adaptation of existing ones in support of the JODI Oil will raise awareness of the significant level of groundwork and ongoing commitment required to arrive at what may at first seem to be a simple 42 point top-level questionnaire response.

### 7.1 Example of practice: Argentina (data submitted to OLADE)

#### Data collection

Argentina is a net oil importer. The legal framework of the country allows private investment in the sector and at present, exploration and exploitation activities are being developed by private investors. Around 50% of the national refining capacity is managed by Repsol-YPF.

In Argentina, there exists a national regulation that upholds the monthly oil information collection, related with production, internal and external markets, stocks, transformation processes at refineries (input/outputs) and demand.

Considering that several private companies operate in the country, the collection process for oil data becomes a little complex. Anyway, the presence of a legal enforcement for this activity, which establishes sanctions for time and format for non compliances, promotes submission of the information within short delays, which do not exceed three months.

Oil companies provide the required information through magnetic or graphic sources. The information related to refining inputs is received as balance formats. The company operator fills the form with "inputs" and "outputs" of the refinery and includes an automatic load balance, on which losses can-not exceed a determined percentage. The balance is not automatically developed by product.

In Argentina, all the operations - imports and exports companies of oil and oil products - are obliged to report their activities. There is no minimum oil volume restriction in order to report the information. It is estimated that the data received are higher than 95%.

If an error or inconsistency is detected with the data provided, the source is contacted and asked to clarify any misunderstanding. However, such occurrences are not common.

#### Data processing and overall assessment of collection system

The method used to insert the data is electronic for all the items in the JODI format, and its storage is done in the particular database. The data collection from the sources is not automatic.

The verification of the validity of the data consists only in assuring that the information comes strictly from the source. An automatic data consolidation is developed only for evident misbalances.

In the case of missing data, an estimation process is developed with a calculation that correlates the percentage variation of the same months of the previous year.

Normally, data are checked on a monthly basis and updated in the database each time it is received.

The information published is in the units required for internal analysis. If information on calorific values and densities are required, the sources are the manuals and publications of the oil ex-state company and conversion factors of OLADE.

In general terms, the collection system for monthly data for oil and products used in Argentina can be defined as acceptable. The Legislation supports the data requirements of the companies, but the difference among data collection methods require different time periods for its processing and compliance control.

## 7.2 Example of practice: Croatia (data submitted to EUROSTAT)

### Data collection

There is legislation in Croatia covering all data flows in monthly oil data collection. The data are collected by means of monthly statistical surveys and from Customs tariff. The surveys are in a balance format. Different surveys are used for different flows.

The data sources and their share in collecting the corresponding data are the following:

- Monthly Survey on Industrial Production (IND-1/MPS form – these data are used also for industrial production volume indices) – 100%.
- Monthly special Survey on Oil Refineries (ERG-1N) – 100%.
- Monthly Survey on Imports, Exports and Stocks Change of Crude Oil and Petroleum Products (ERG-2N) – approximately 95%.
- From other sources - Customs tariff – approximately 5%.

The data providers are contacted to verify if mistakes / inaccuracies or suspicious numbers are noticed, but there are no regular meetings with them to discuss the methodology. Meetings are organised only as needed.

Mandatory data providers cover approximately 95% of the data.

Oil data are not collected for any other international or national purposes with different methodology than the one in JODI Oil.

### Data processing and overall assessment of collection system

The data are manually entered into the system, but there is no database.

The accuracy of the verification of the data is carried out by comparing the data with Customs tariff and with previous months. Also logical control of data is carried out against expected lower and upper limits of flows of certain energy-generating products.

Usually all data are collected and estimates are rarely made under the Customs tariff. Revisions to the data are accepted, but they are rarely incorporated.

The data are published in different units as needed. The IEA conversion factors are used.

The overall assessment of the data collection system is good. The coverage of the imports and exports data is 95%, and the coverage of the production data of oil derivatives is 100%

### Suggested improvements include the following points:

The system could be better if there were a database in which all energy data, not only JODI Oil data, could be stored.

### 7.3 Example of practice: Egypt (data submitted to UNSD)

#### Data collection

Egypt's first participation in the JODI Oil project was in May 2002 in Mexico City. Since then, Egypt has developed and adapted its system and processes to assure reporting quality data on time (which is M-1), and to achieve the best level regarding the main criteria for Data Quality Assessment, i.e. data coverage, completeness, timeliness and accessibility.

In order for Egypt to achieve M-1, it was essential to map its data flow processes. All unnecessary steps and bottlenecks that caused delay were modified and eliminated. In the modified process it currently takes 21 days to submit the data and to evaluate it in the Egypt Petroleum Corporation (EGPC). Currently, the whole data handling process takes about one month to report M-1 data.

The following points summarize the main steps for the current data flow:

- The data flow starts from the fields and the companies to the concerned division in EGPC. Daily data checked, tabulated and loaded on the mainframe. Data are checked for coverage, completeness and up-loaded in specific format; necessary conversion is made to a standard format.
- Data are checked: the absolute value is graphically displayed; data comparison recognizes deviations, gaps and defined reasons for these gaps.
- Data are reported and delivered in the required report to the concerned higher levels.

#### Data processing and overall assessment of collection system

Data coverage: 95 oil companies are currently working in Egypt, with some of them in the private sector. 95% of the oil market currently reports data.

Data completeness: About 90% of the required data, such as crude oil and petroleum product production, export, import and demand are reported on a monthly basis. Stock level is not available on a monthly basis.

Data accuracy: Quality control is done through analyzing the actual versus target values, and comparing data, including historical data, with the same period the year before. Also assessing the accuracy of the data is done through the absolute and percentage deviations with  $\pm 5\%$  tolerable deviation, which is an acceptable level of estimation. In order to accelerate the data accuracy checks, data are required to be submitted in a balance format and checked with internal consistency. Data are currently controlled by the least three hierarchical levels.

Data Accessibilities: Through the existing network data becomes easily accessible by users. It is also adequately documented and available in the form users desire.

#### Suggested improvements include the following points:

It is still recognised that there are some criteria which need improvement such as completeness, raised level of data accuracy, standardised conversion factors measurement's units between companies and the provision of adequate training for statistical analysis.

## 7.4 Example of practice: France (data submitted to IEA)

### Data collection

France has a legislation underpinning its monthly oil data collection, which covers all JODI Oil data flows, i.e. production, imports, exports, stocks, refinery intake/output and demand. The 1992 French law on liberalization of the oil sector includes an article on oil statistics, and the 2005 program law sets the orientations of the energy policy. Other statistics stem from professional lobbies, which collect data from their members (e.g. oil distributors) on the basis of a gentleman's agreement. These professional bodies publish data on markets, which are of great interest to their members. These bodies also provide many more services to their members. Overall, participation of companies is good.

The sources of data are surveys on refinery activities (balance format + consistency control), crude oil import (consistency control) and deliveries (balance format). A portion of French data is estimated (e.g. external trade for JODI Oil M-1). A combination of surveys and other sources can also be used if, for instance, only annual data are available (petrochemical industry, etc.).

There is a threshold of €150 000 in trade per year or 1 tonne from which it becomes mandatory for all importers to report their data. Regarding LPG deliveries, there is a monthly survey for the companies' members of the CFBP (professional lobby) as well as an annual survey on non-members (= 1% of the total LPG deliveries). Other surveys are exhaustive.

Oil data are collected for other international or national purposes with different methodology than the one in JODI Oil. The definition is different for crude oil imports and companies usually use a different database to submit the JODI Oil and the MOS (Monthly Oil Statistics). Moreover for JODI Oil, deliveries operated by storage facilities are readily available whereas for MOS, it is companies' sales.

On average, there is no difference between sales and deliveries. Differences occur every month only because both flows are measured at different steps of the chain. Sales are preferred because they can be split by regions and because they correspond to financial flows.

When mistakes/inaccuracies or suspicious numbers are noticed, the French Authorities contact the data provider to verify. Regular meetings with data providers, users, and experts take place, and surveys are run together with the professional lobby UFIP (Union Française des Industries Pétrolières).

### Data processing and overall assessment of collection system

The method of data entry is mainly electronic for all flows and data are stored in two databases: ORNOIR and PEGASE. Methods for verifying data accuracy are very precise global controls on demand, according to climatic conditions, and other individual controls (controls on companies answers, see above). Missing data are estimated using two different methods:

- To estimate small figures, the previous data available;
- For large figures, estimation may be made more precisely, according to the past evolution, the number of days of the month, etc.

Data revisions are incorporated in the database at any time, but only if they are fully justified. Data are published in tonnes and in toe, using conventional conversion factors.

The overall assessment of the French JODI Oil monthly data collection system has been classified as good, the most important positive point being that its whole system utilises data that were already available. In 95% of the cases, for the activity of refineries, there is a harmonization between their reporting systems and that of the customs office. A negative point of the French JODI Oil collecting system is that it relies on only one person.

### Suggested improvements include the following points:

- Working data on foreign trade of products early enough for JODI Oil.

## 7.5 Example of practice: Norway (data submitted to IEA)

### Data collection

Norway has a centralised system, where the national statistical office (Statistics Norway) is responsible for energy statistics in general and oil statistics in particular. The mandate of Statistics Norway is broad and also covers energy statistics. Energy statistics is a sectoral statistics, similar to industrial statistics, trade statistics or agricultural statistics etc., which all have their role and are part of official statistics on their own while they also have to feed into the national accounts. Statistics Norway has its mandate defined by a Statistics Act, which enables them to access all relevant data from providers whom they find appropriate, including data from governmental institutions. This means that compiling oil and gas data on production, trade, stocks, refinery intake/output, demand, etc. is covered by the legislation.

The statistical office is not a user of statistics itself, but fulfils its mandate based on the needs in society. However, there are some indirect internal uses of oil statistics in producing the energy balance and the national accounts.

For inland consumption of petroleum products the statistical act is not used, but Statistics Norway produces these statistics on behalf of the industry as a part of their needs. Statistics Norway is chosen because it is an independent actor with good production routines and systems. This is an example of how companies might be convinced to provide data in the absence of legislation.

The government regulates the oil business, and the Norwegian Petroleum Directorate (NPD) carries out the exercising role. Major players are, besides the NPD, relatively few retail companies, refineries and stock terminals. The system consists mainly of few large bodies, which makes a good overview, and short distance between the data providers and the statistical office. NPD collects all relevant data from the oil producing companies, which is forwarded to Statistics Norway. There is close cooperation between NPD and Statistics Norway, which is a huge advantage, due to their expertise and knowledge about the market.

At the time of the JODI Oil reporting, neither figures for indigenous production from NPD nor export figures are final, and a few stock figures may be missing for certain fields. The preliminary production figures from NPD are however quite accurate, and not far from the final reports. Missing crude oil and NGL stock figures from the NPD are estimated, by taking an average of the last 5 months. This is not a very accurate method, but it does not cause great deviations, as any missing stock figures usually are caused by minor fields. Crude oil and NGL export figures are for the JODI Oil report collected from Statistics Norway's division for external trade, which base their statistics on custom bills. In addition, a smaller part of the NGL export figures are only available from the NPD as they are not covered by the customs. This is for the exports of Norwegian NGL from the British sector. These have to be estimated at M-1 level, but as they are relatively stable from one month to another they put the figure from the previous month.

All estimated figures are revised the next month, for the M-2 period.

For inland consumption of refined petroleum products a survey is used. The retailing companies report, by the 10<sup>th</sup> after the reference month, their sales of each product, distributed by the different consumer groups. This is done by using data files with a pre-defined format.

Refineries and terminals report production, consumption and stock figures by the 20<sup>th</sup> of each month after the reference month. This is reported in Excel spreadsheets, with formats defined by Statistics Norway.

Import/export data for refined products are collected directly from the database of the Division for external trade (which again comes from custom bills).

Production, export and stock figures for crude oil, NGL and natural gas from the upstream sector are reported in Excel spreadsheets from the NPD, and processed by Statistics Norway.

All import and export data are collected by the customs offices, and forwarded to Statistics Norway.

Distributors report their sales voluntarily, but they get reports from both the large actors and some minor players, which hold less than a percent. Loads imported by these distribution companies are subtracted from the import volumes to avoid double counting. The national distributors that report voluntarily cover more than 95% of all inland consumption, while the rest is net import from the foreign trade and cannot easily be distributed on consumer groups.

Statistics Norway also reports Monthly Oil Statistics to IEA, mainly using the same methodology as for JODI. The MOS report contains more data than what is submitted to JODI, as the MOS report is compiled on an M-2 basis.

Norway, as a member of EUROSTAT, reports National Account figures. These include economic statistics for oil activity, which is collected by using a detailed set of questionnaires in an annual survey of the oil companies on the Norwegian Continental Shelf.

Oil data from the NPD is also collected by Statistics Norway's division for Environmental statistics for use in the Environmental Accounts and in the Energy Accounts/Balances, and by the Division for Economic Indicators for use in the production index. The different divisions collect different data, and use to some extent different processing methods and different definitions, but they keep internal consistency. The product definitions in the JODI Oil-reports deviate from the product definitions in the National Accounts. This creates some confusion for their users, as the published figures are not always comparable, and it also creates some difficulties in international harmonization.

In case of mistakes, inaccuracies or suspicious numbers the data providers are contacted by the IEA. Statistics Norway has regular meetings with the branch organisation for the sales companies where methodology is discussed. Further, they have a close relation and regular contact with the NPD.

### **Data processing and overall assessment of collection system**

The method of data entry is manual, with extensive use of formulas in Excel spreadsheets. For inland consumption of products, data are kept in a database. Other data are kept in their original files.

Accuracy of data is verified by comparing with previous month, and by assessing reasonability. Furthermore, the internal users of oil data constitute an important part of the verification process, particularly in the work with the Energy Balance. To some degree they estimate missing data. Missing stock figures for crude oil are estimated by using an average of the last 5 months, while missing import/export data for a smaller part of the total of NGL are estimated by using the figure for the previous month. Indigenous production figures for the period M-1 are estimated by the NPD, and is close to the final level.

In general, Statistics Norway does not revise monthly data. JODI Oil data for M-1 are revised the next month for period M-2 and in the MOS. Final figures are reported annually in the AOS and AGS (respectively Annual Oil Statistics and Annual Gas Statistics), and might deviate from the sum of MOS. If deviation is due to errors in the processing, reports are revised. Minor deviations in consumption and production are not revised, as there will always be some disparity. Data on refined petroleum products are published in litres. Historical conversion factors are used to convert to tons. Other data are received in the required units.

Due to the fact that Norway has a centralised administration for collection of national oil production statistics, the reporting units are to a great extent centralised. This situation gives a good overview of the energy sector. The fact that the data providers are few creates good possibilities for contact between Statistics Norway and the industry, as well as for quality controls and checks to be done. This situation gives Statistics Norway confidence that the data and the reports are of high quality.

### **Suggested improvements include the following points:**

Statistics Norway is continuously working on improving the reports and their methods, and they are considering the possibilities of implementing a higher degree of automation. Using databases and program applications would lighten the work, and increase the confidence. It would also facilitate revisions, as the reports are made manually today, with a high degree of separate calculations.

Reporting and monthly revisions would be facilitated if the reports were built according to the annual reports' standards, that is to say with the possibility of reporting in time series.

## 7.6 Example of practice: Philippines (data submitted to APEC)

### Data collection

The Philippine downstream oil industry has been deregulated by virtue of Republic Act 8479 otherwise known as the "Downstream Oil Industry Deregulation Act of 1998". This law defined the policy of the State to liberalise and deregulate the Philippine downstream oil industry in order to ensure a truly competitive market under a regime of fair prices, adequate and continuous supply of environmentally-clean and high quality petroleum products.

The law and its Implementing Rules and Regulations (IRRs) serve as the guidelines for the various petroleum downstream activities in the country. Figure 7.1 shows the flow of activities in the Philippine Downstream Oil Sector.

Figure 7.1 Downstream oil sector

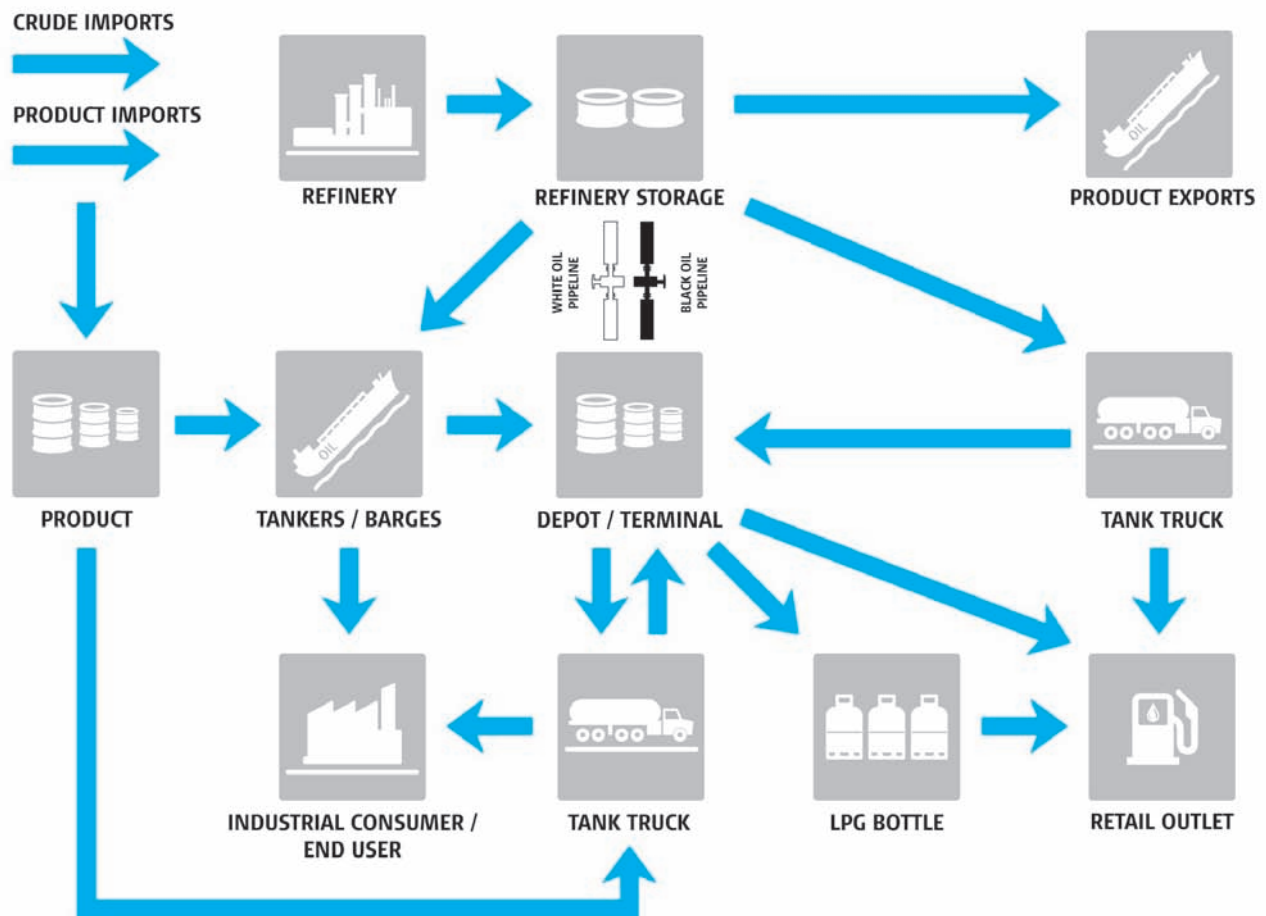

Downstream petroleum statistics are sourced directly from the participants in the industry and even importers for own use, e.g. airline companies. Rule II - Section 7 of the IRR requires the industry participants to submit various reportorial requirements to the OIMB (Oil Industry Management Bureau).

The monthly and annual reportorial requirements are submitted on or before the 15th day of the month following the month covered by the monthly report and not later than the 15th day of January of the year following the year covered by the annual report. These reports are submitted to OIMB through electronic mail, facsimile or directly delivered by messenger or via ordinary mail.

On the other hand, upstream data such as crude oil/condensate production and other upstream activity reports are covered by Presidential Decree 87, otherwise known as the "Oil Exploration and Development Act of 1972". The Energy Resource Development Bureau of the DOE (Philippines Department of Energy) is handling the monitoring activity for the petroleum upstream sector.



As part of its daily price monitoring functions, the DOE subscribes to oil-related information from an authoritative provider of energy information like Platts, which is an internet-based news and price assessment service. The DOE subscribes to Mean of Platts Singapore (MOPS) spot price for crude oil (Dubai) and refined petroleum products to understand price and market trends in the international market, and then relate this to the movements in the local oil industry.

The DOE seldom employs survey type of reports. However, through collaboration with another government agency (National Statistics Office), the DOE conducts the Household Energy Consumption Survey (HECS) every five (5) years. The primary objective of HECS is to gather data on household energy consumption, application and other relevant factors affecting such consumption.

The OIMB calls the attention of the player to the late submission of reports or non-compliance of the same. Failure to comply with submission of any reportorial requirements as provided under Chapter III - Section 12 of the Deregulation Act penalizes any person, including but not limited to the chief operating officer or chief executive officer of the partnership, corporation or any entity involved, with imprisonment for two (2) years and fine ranging from Two Hundred Fifty Thousand Pesos (P250,000.00) to Five Hundred Thousand Pesos (P500,000.00). [One Peso was around 2.4 US cents in 2012.]

The Petroleum Institute of the Philippines conducts monthly meetings of its members and assists DOE as necessary.

In case of inaccuracies or suspicious numbers, the DOE asks the data provider to clarify and/or revise the questionable figures as the case may be.

There are other DOE units which submit reports (which include data from OIMB) to international institutions such as APEC but with different report format, coverage (includes other energy sources) and units (metric tons) than those submitted by OIMB to JODI Oil which only cover data on oil. On the other hand, the DOE also provides data to other local government agencies e.g. Bureau of Customs (BOC), Central Bank of the Philippines – Development Budget Coordination Committee (DBCC) and the National Economic Development Authority (NEDA) among others.

However, as a matter of policy, the DOE only provides industry data per Section 15g of the "Downstream Oil Industry Deregulation Act of 1998" to observe confidentiality of data/information submitted and/or provided to the DOE, thereby encouraging the trust and confidence of data providers.

### **Data processing and overall assessment of collection system**

Processing/entry of data is done manually and encoded in Excel-based worksheets for consolidation. Database files are not yet available. However, the DOE through its Information and Technology Management Services (ITMS) is currently studying on-line submission of reports of the oil players. The OIMB has also previously asked the ITMS to design a database program for the consolidation and processing of downstream oil statistics.

Upon receipt of reports, the DOE verifies/evaluates the veracity of the monthly and annual reports submitted by the data providers by comparing these reports with their historical trends/records. Also, validation of import data reported vis-à-vis submitted post shipping documents is also being done. Occasionally, the DOE also conducts visual inspections of the different crudes and petroleum products facilities to verify existing stocks, import arrivals and gather other relevant information as well. With the deregulation of the industry, however, some reports could not be validated and perhaps some numbers are not captured.

In case of missing data because of late and/or non-submission of reports of some data providers, an estimated figure is computed based on their yearly/monthly average data. Figures are revised with corrections incorporated upon receipt of the actual documents (i.e. final invoices) in the next monthly update.

The Philippine Energy Plan (PEP) which is regularly updated/published by the DOE provides for converted energy forms into a common unit, barrels of fuel oil equivalent (BFOE), based on fuel oil heating value equivalent at 18,600 BTU/lb. For OIMB's use, however, conversion factors available in such required documents as Bill of Lading are used.

Data coverage: With the deregulation of the Downstream Oil Industry since 1996, 186 additional new players (in various specific downstream activities) have joined the industry. This makes data collection more complicated with the increased number of reporting players as compared to only three (3) major oil companies previously existing during the regulated regime.

Data timeliness: With no definitive penalty for late submission of reports, some information providers would occasionally submit very late for a variety of reasons. Usually, there is one month backlog in report collection and two months backlog for the processing and release of a final consolidated monthly report.

Data accuracy: New players would not initially fully understand some of the reports' requirement and would often submit inaccurate figures. Delayed availability of some final documents cause the data provider to submit estimated figures instead of actual just to beat the specified deadline.

**Suggested improvements include the following points:**

- Strengthening enforcement authority of DOE. There is a proposed bill which seeks to address unjustified and/or delinquent compliance to the reportorial requirements through definitive penalties and restoration of DOE's authority and police power to suspend operations and revoke licenses of violators and to correct erring players in the industry. The existing provision only provides penalties for those who refuse to comply.
- Enhancing communication with data providers through constant coordination and cooperation, instilling the importance and significance of the generation and maintenance of timely, reliable and accurate oil statistics.
- Coordinating and cooperating with the ITMS to facilitate the database development and operation to further improve data collection, validation, processing, and report generation.
- Requesting additional budget to improve/upgrade the existing computer network capability.

## 7.7 Example of practice: Saudi Arabia (data submitted to OPEC)

### Data collection

Saudi Arabia has legislation underpinning its monthly oil data collection which covers all JODI Oil data flows, i.e. production, imports, exports, stocks refinery intake/output and demand. The sources for all data flows are surveys. Saudi (JODI Oil) data are not collected in a balance format.

Oil exporters are obliged to report their data to Saudi Authorities. This regulation applies also to small volumes of traded oil; hence there is no minimum volume from which reporting becomes mandatory and all (100%) reported data are received on a mandatory basis. In cases of data mistakes or inaccuracies the country contacts the data provider for clarification. There are also regular meetings with data providers (once a year), which focus on the discussion of the data methodology.

### Data processing and overall assessment of collection system

The method of data entry is electronic for all flows and all data are stored in a database.

Methods for verifying data accuracy are basic edit and range checks, comparisons to previous periods and flag reports if figures exceed a specified percentage tolerance. Missing data are (rarely) estimated by using different methods, which depend on the specific flow and product.

Data revisions are regularly received and are incorporated in the database on average four times a year. Data are also published/or received in different units – conversion takes place by the use of standard conversion factors at the country level.

In general the overall assessment of the Saudi (JODI Oil) oil monthly data collection system has been classified as very good with the most important positive points being its reliability, timeliness and its highly automatic functioning capability. A negative point of the Saudi JODI Oil collecting system is its complexity.

# Chapter 8: The JODI Oil World Database

---

## 8.1 Background

The JODI Oil World Database is the visible part of the Joint Organisations Data Initiative, but JODI is much more than collecting and releasing monthly oil statistics. JODI has played an important role in raising political awareness of the difficulties encountered in improving data reliability and timeliness. Networks have been established and statistical systems have been improved in many countries. Attitudes towards confidentiality and reliability have evolved. Contacts among oil companies, countries and organisations have multiplied. JODI has also strengthened producer-consumer dialogue by demonstrating that dialogue is not only a concept, but can lead to concrete action.

The release of the JODI Oil World Database was not the primary goal of the initiative; however, since transparency is central to the initiative, the seven international organisations behind JODI: APEC, Eurostat, IEA, IEF, OLADE, OPEC and UNSD agreed to open the JODI Oil World Database on the occasion of the inauguration of the new IEF headquarters on 19 November 2005. This decision was taken with the full knowledge that users might be disappointed, as not all the data for all the flows, products and countries are always available, or of good quality.

The opening of the database is not the final goal of the initiative either. The database should improve continuously and several initiatives will soon be launched to further strengthen reporting expertise in countries and to raise political awareness.

## 8.2 Building the JODI Oil World Database

The six international organisations responsible for the JODI Oil data collection assemble their member country's data each month and send it to the IEF. Data quality issues relating to member country's data are handled by each organisation, and each organisation is responsible for the data quality of its member country's data.

The IEF gathers the data from the six organisations and carries out some additional checks. Moreover, data are converted into common units, so that they become comparable, as each organisation is collecting the JODI Oil questionnaire data in the unit they use for other oil questionnaires.

Once data are verified and converted, the IEF then updates the JODI Oil World Database on a monthly basis and makes it publicly available on the JODI website.

Figure 8.1: Dataflow to the IEF

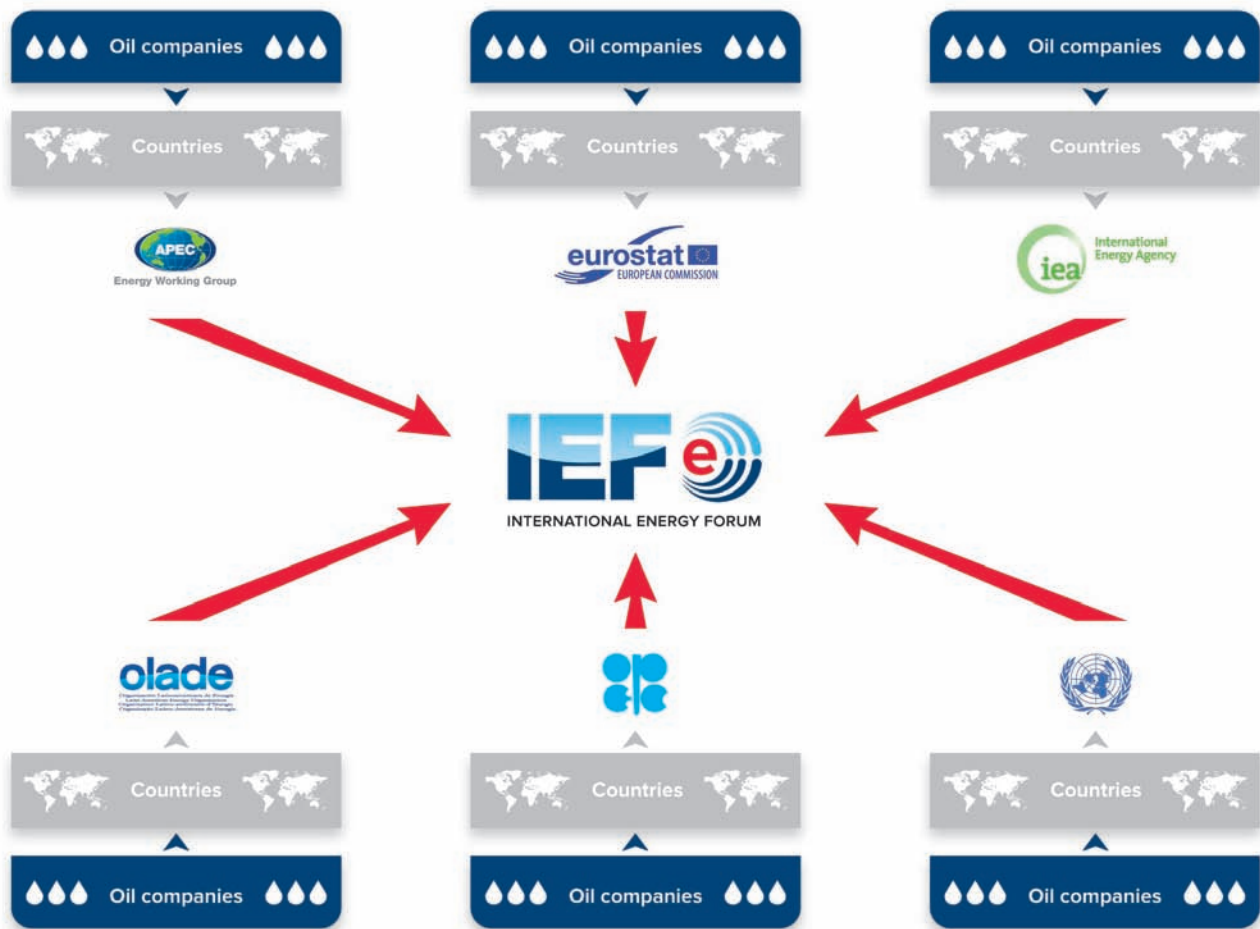

## 8.3 The JODI Oil World Database

### 8.3.1 How to access?

The JODI Oil World Database is accessible on the JODI Website. The website address is as follows:  
<http://www.jodidata.org>

Extensive background information as well as full explanations are provided on the website.

The data are presented using the Beyond 20/20™ browser software, available for downloading at the site.

### 8.3.2 What is included?

- Thirteen **product** categories: Crude oil, NGL, Other (refinery feedstocks + additives/oxygenates + other hydrocarbons), Total (primary products), LPG, Naptha, Motor/aviation gasoline, Kerosenes, of which: Kerosene type jet fuel, Gas/diesel oil, Fuel oil, Other oil products and Total oil products.
- Fourteen **flows**: Production. From Other sources, Trade, Products transferred/Backflows, Direct use, Stock change, Statistical difference, Refinery intake, Closing stocks, Refinery output, Receipts, Products transferred, Interproduct transfers, Demand.  
Data are available in three different units : barrels, tons and litres.
- Conversion factors are available.
- Data are for more than 90 participating **countries**.
- History from January 2002: target is to release one month old data every month from all participating countries.

### 8.3.3 Some features

Transparency is the key word behind JODI; the database was designed with the goal of transparency squarely in focus:

- Choice to browse data online or download data files in Beyond 20/20 format
- Colour coding has been given to data cells to indicate the confidence evaluations of the data where possible (see below)
- Easy graphic representation
- Easy manipulation of products, flows and units
- Choice of language: English, French, German and Spanish
- Data downloadable in different formats, including the colour coding when downloading to Excel from a Beyond 20/20 format

Figure 8.2: A view from the database

### 8.3.4 Colour coding

A unique colour cell feature provides the user with supplementary information on the assessment made:

- **BLUE:** A blue background indicates that results of the assessment show reasonable levels of comparability with other sources;
- **YELLOW:** a yellow background indicates that the Metadata should be consulted;
- **WHITE:** a white background indicates that data has not been assessed;
- **PURPLE:** data under verification.

How was the colour coding derived? The assessment of the data was carried out on different levels:

- Comparability of the JODI Oil data with other sources: monthly data from national and secondary sources has been assessed.
- JODI Oil data have also been compared with annual data (when available) in order to check whether the levels and trends over the years could be confirmed.
- When no other sources were available for comparison with the JODI Oil data, internal consistency and balance checks have been carried out.

The IEF conducts internal data consistency checks in its monthly procedure to update the JODI Oil World Database. Any outstanding issues will be shared with JODI organisations. If the IEF identifies obvious errors which have not already been flagged by the "Use with caution" colour code as set by the JODI organisation responsible for the country in question, a purple code "Data under verification" will be applied until such time as the organisation responds to the IEF with a satisfactory response.

Examples of internal consistency checks: the sum of all the reported products with reported figures for Total Oil Products is compared. When both closing and stock changes data have been submitted, the consistency of the reported changes with the calculated ones is compared (See Chapter 5.2.1.2).

Example of balance check: The JODI Oil questionnaire does not collect full balance information. However some basic checks for reasonableness can be carried out e.g. supply + import - export + stock change should have a relation with demand (See Chapter 5.2.1).

*Remark:* For IEA/OECD countries, data in the JODI Oil database are the MOS data for all months except data shown for M-1. Comparability for the last month has been derived from comparison with MOS data. This methodology is applied using a rolling 12 month period.

# Annex 1: The refinery process

Crude oil in the state it is produced is not usable for most purposes. Although it can be burned directly in power generation plants, it cannot be used in cars or trucks.

To optimise the use of crude oil, it needs to be converted into several other products; this happens in a refinery. The market demand for oil products will not only dictate the optimal output of a refinery, but also the type of crude which will be used and processed to produce the required output.

Crude oil is a mixture of many different hydrocarbons and small amounts of impurities. The composition of those raw materials can vary significantly depending on its source. Petroleum refineries are complex plants where the combination and sequence of processes is usually very specific to the characteristics of the raw materials (crude oil) and the products to be produced. A refinery takes crude oil and **separates** it into different fractions, then **converts** those fractions into useable products, and these products are finally **blended** to produce a finished product. These finished products are the fuels and chemicals used every day.

In a refinery, portions of the outputs from some processes are fed back into the same process, fed to new processes, fed back to a previous process or blended with other outputs to form finished products. One example of that can be seen in the chart below. However, refineries are different regarding their configuration, process integration, feedstock, feedstock flexibility, products, product mix, unit size and design and control systems.

Figure A1.1: Operation of a typical refinery

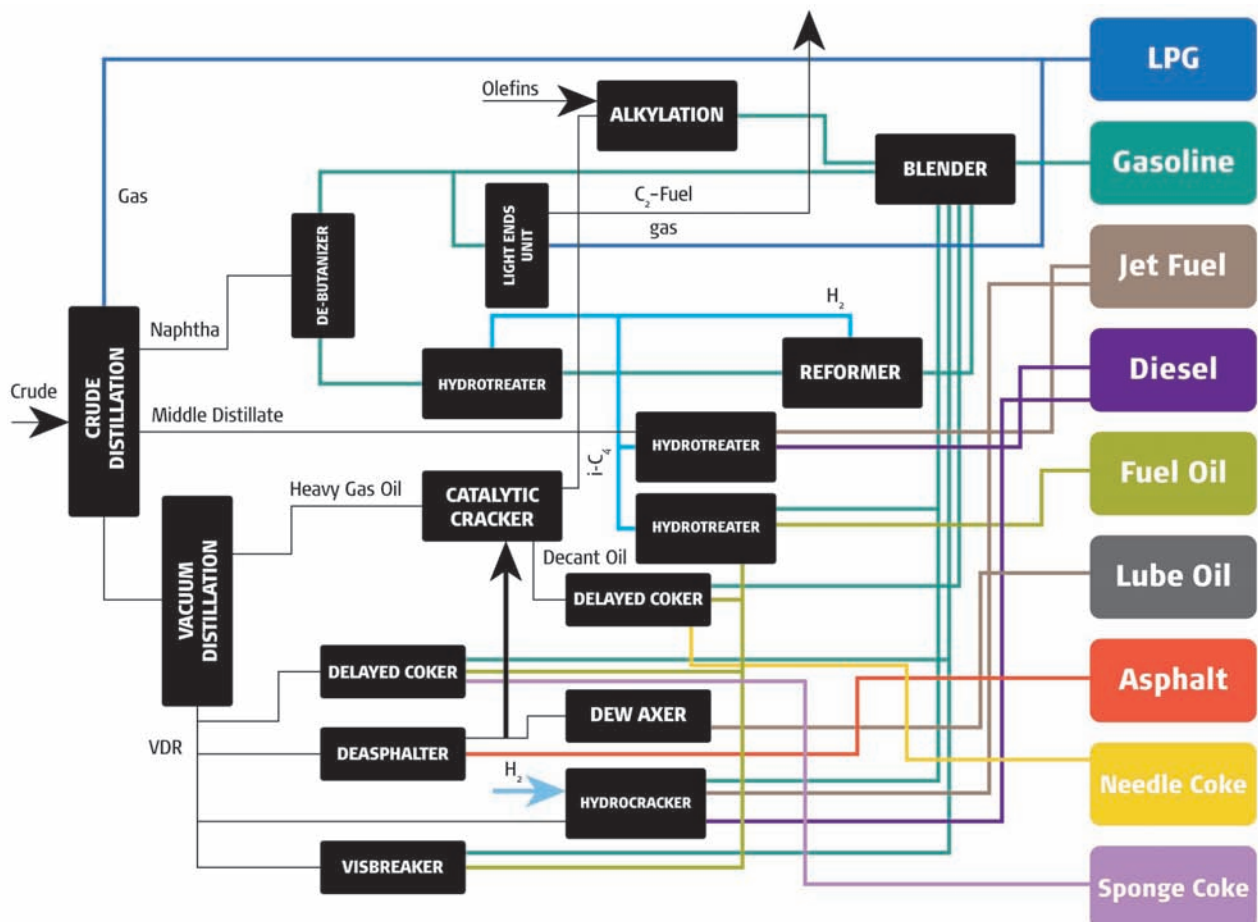



In addition, differences in an owner's strategy, market situation, location and age of the refinery, historical development, available infrastructure and environmental regulation are amongst other reasons for the wide variety in refinery concepts, designs and modes of operation. The environmental performance can also vary from refinery to refinery.

The production of a large number of fuels is by far the most important function of refineries and will generally determine the overall configuration and operation. Nevertheless some refineries can produce valuable non-fuel products such as feedstocks for the chemical and petrochemical industries. Examples are mixed naphtha feed for a steam cracker, recovered propylene, butylene for polymer applications and aromatics manufacture. Other specialty products from a refinery include bitumen, lubricating oils, waxes and coke. In recent years the electricity boards in many countries have been liberalised allowing refineries to feed surplus electricity generated into the public grid.

Refining crude oil into usable petroleum products can be separated into two phases and a number of supporting operations. The first phase is desalting of crude oil and the subsequent **distillation** into its various components or 'fractions'. A further distillation of the lighter components and naphtha is carried out to recover methane and ethane for use as refinery fuel, LPG (propane and butane), gasoline blending components and petrochemical feedstocks. This light product separation is done in every refinery.

The second phase is made up of three different types of 'downstream' processes: **combining, breaking and reshaping** fractions. These processes change the molecular structure of hydrocarbon molecules either by breaking them into smaller molecules, joining them to form larger molecules, or reshaping them into higher quality molecules. The goal of those processes is to convert some of the distillation fractions into marketable petroleum products through any combination of downstream processes. Those processes define the various refinery types, of which the simplest is the 'Hydroskimming', which merely de-sulphurises and catalytically reforms selected outputs from the distillation unit. The amounts of the various products obtained are determined almost entirely by the crude composition. If the product mix no longer matches the market requirements, conversion units have to be added to restore the balance.

Market demand has for many years obliged refineries to convert heavier fractions to lighter fractions with a higher value. These refineries separate the atmospheric residue into vacuum gasoil and vacuum residue fractions by distillation under high vacuum, and then feed one or both of these outputs to the appropriate conversion units. Thus by inclusion of conversion units, the product slate can be altered to suit market requirements irrespective of the crude type. The number and the possible combinations of conversion units are large.

The simplest conversion unit is the thermal cracker by which the residue is subjected to such high temperatures that the large hydrocarbon molecules in the residue convert into smaller ones. Thermal crackers can handle virtually any feed, but produce relatively small quantities of light products. An improved type of thermal cracker is the coker, in which all the residue is converted into distillates and a coke product. In order to increase the degree of conversion and improve product quality, a number of different catalytic cracking processes have evolved, of which fluid catalytic cracking and hydrocracking are the most prominent. Recently residue gasification processes have been introduced within refineries, enabling them to eliminate heavy residues completely and to convert them into clean synthetic gas for refinery use and production of hydrogen, steam and electricity via combined cycle techniques.

# Annex 2: Units and conversion factors

---

## Introduction

The most common units employed to express quantities of fuels and energy are those relating to volume, mass and energy. The actual units employed vary according to country and local conditions and reflect historical practice in the country, sometimes adapted to changing fuel supply conditions.

This annex will firstly describe the various units in use and their interrelationships in general, and it will then provide for more specific information on units and conversion factors for oil.

## 1 Units and their interrelationships in general

The internationally recognised units which cover almost all of the measurements of fuel and energy quantities are the cubic metre, tonne (metric ton) and joule. These are the SI units.<sup>1</sup> However, over many years other units have been used and the sections below will list their relationships where they are well defined.

### 1.1 Decimal system prefixes

The following table gives the most common multiple and sub-multiple prefixes used in oil statistics. Note that the prefixes should be used exactly as given. In particular, prefixes in lower case should never be written as upper case. For example, a figure expressing x kilowatts should be written as x kW, never x KW.

**Table A2.1 Most common multiple and sub-multiple prefixes**

10 <sup>1</sup>	deca (da)	10 <sup>-1</sup>	deci (d)
10 <sup>2</sup>	hecto (h)	10 <sup>-2</sup>	centi (c)
10 <sup>3</sup>	kilo (k)	10 <sup>-3</sup>	milli (m)
10 <sup>6</sup>	mega (M)	10 <sup>-6</sup>	micro (μ)
10 <sup>9</sup>	giga (G)	10 <sup>-9</sup>	nano (n)
10 <sup>12</sup>	tera (T)	10 <sup>-12</sup>	pico (p)
10 <sup>15</sup>	peta (P)	10 <sup>-15</sup>	femto (f)
10 <sup>18</sup>	exa (E)	10 <sup>-18</sup>	atto (a)

---

<sup>1</sup> They are derived from the metre, kilogramme and second included in the *Système International d'Unités* and serve as an international basis for science, technology and commerce.

## 1.2 Conversion equivalents

### Units of volume

The unit of length underlies the unit of volume. 1 inch is defined as 25.4 millimetres.

The gallon and litre were originally standards of liquid measure but are now formally defined in terms of the cubic metre. In the oil business, the barrel is the most frequently used unit of measure in North America, whereas the cubic metre is more frequently used in the Asia Pacific region.

**Table A2.2 Conversion equivalents between units of volume**

To:	gal U.S.	gal U.K.	bbl	ft <sup>3</sup>	l	m <sup>3</sup>
From:	Multiply by:					
U.S. gallon (gal)	1	0.8327	0.02381	0.1337	3.785	0.0038
U.K. gallon (gal)	1.201	1	0.02859	0.1605	4.546	0.0045
Barrel (bbl)	42.0	34.97	1	5.615	159.0	0.159
Cubic foot (ft <sup>3</sup> )	7.48	6.229	0.1781	1	28.3	0.0283
Litre (l)	0.2642	0.220	0.0063	0.0353	1	0.001
Cubic metre (m <sup>3</sup> )	264.2	220.0	6.289	35.3147	1000.0	1

### Units of mass

The SI unit of mass is the kilogramme (kg) and the tonne (metric ton), equal to 1 000 kilogrammes, is widely used as the smallest unit in energy statistics. For most countries the national commodity balances will use the kilotonne (1000 tonnes) as the unit for presentation of commodities expressed in mass terms.

**Table A2.3 Conversion equivalents between units of mass**

To:	kg	t	lt	st	lb
From:	Multiply by:				
kilogramme (kg)	1	0.001	$9.84 \times 10^{-4}$	$1.102 \times 10^{-3}$	2.2046
tonne (t)	1000	1	0.984	1.1023	2204.6
long ton (lt)	1016	1.016	1	1.120	2240.0
short ton (st)	907.2	0.9072	0.893	1	2000.0
pound (lb)	0.454	$4.54 \times 10^{-4}$	$4.46 \times 10^{-4}$	$5.0 \times 10^{-4}$	1

### Energy units

The SI unit of energy is the Joule (J). Many other units for energy are in use for the practical expression of energy quantities partly for historical reasons and partly because the small size of the joule demands the use of unfamiliar (for non scientists) decimal prefixes.

Historically the ton of coal equivalent was used but, with the ascendance of oil, this has been largely replaced by the tonne of oil equivalent (toe) defined as 41.868 gigajoules<sup>2</sup>.

There are several other energy units in use; for example the *calorie* with a conversion equivalent between the calorie and the joule given by the International Steam Table (IT) which is defined to be 4.1868 joules. Similarly, the internationally agreed value for the British Thermal Unit (Btu) is now 1055.06 joules. The Btu is the basis for the Quad ( $10^{15}$  Btu) and the Therm ( $10^5$  Btu).

**Table A2.4 Conversion equivalents between units of energy**

To:	TJ	Gcal	Mtoe	Mbtu	GWh
From:	Multiply by:				
TJ	1	238.8	$2.388 \times 10^{-5}$	947.8	0.2778
Gcal	$4.1868 \times 10^{-3}$	1	$10^{-7}$	3.968	$1.163 \times 10^{-3}$
Mtoe	$4.1868 \times 10^4$	$10^7$	1	$3.968 \times 10^7$	11630
Mbtu	$1.0551 \times 10^{-3}$	0.252	$2.52 \times 10^{-8}$	1	$2.931 \times 10^{-4}$
GWh	3.6	860	$8.6 \times 10^{-5}$	3412	1

## 2 Units and their interrelationships for oil

### 2.1 Mass and volume

Oil is mostly measured by its **mass** or **volume**. Within each of these measurements, several units are used in the oil industry:

- The most widely used unit of mass (weight) to measure oil is the metric ton (or tonne). For instance, tankers in the oil industry are often described based on their capacity in tons, where an Ultra Large Crude Carrier (ULCC) is defined as being able to carry over 320,000 tons.
- The original unit for most liquid and gaseous fuels is volume. Oil can be measured by the litre, the barrel, or cubic metre. A common example of the use of volume as the unit of measurement is in the price of oil, quoted in dollars per barrel.

Because crude oil contains a wide range of hydrocarbons from the lightest to the heaviest, the characteristics including the density of individual crude oils vary greatly. Similarly, the density of the different petroleum products varies substantially between the products.

The density can be used to classify petroleum products from light to heavy, where for example LPG is considered light at 520 kg/m<sup>3</sup> while fuel oil is a heavy product at over 900 kg/m<sup>3</sup>.

To convert from mass into volume or vice versa, the specific gravity or density of the oil must be known. Without going into too much technical detail, a few terms need to be explained in order to understand oil conversion factors.

**Density** is defined as mass per unit volume, i.e. ton/barrel. The **specific gravity** is the relative weight per unit volume (or density) of a given substance compared to that of water. The density of water is 1g/cm<sup>3</sup>. Motor gasoline for example has a lower density as it is much lighter for the same volume. The specific gravity of motor gasoline is therefore smaller than 1. Since volume changes with changes in temperature, data on specific gravity are made with a reference to a specific temperature (for petroleum, the reference is usually 15 degrees Celsius). Moreover, specific gravity is often quoted as a percentage e.g. a specific gravity of 0.89 is shown as 89.

The term **API gravity** (a standard adopted by the American Petroleum Institute) is commonly used to express the specific gravity of petroleum.

For information, API gravity is defined as:  $( 141.5 / 60^\circ \text{ specific gravity at } 60^\circ \text{ F} ) - 131.5$ .

The result is an arbitrary scale for measuring gravity, expressed in degrees API, where the lighter a compound is, the higher its degrees of API gravity. For example, what are considered light crudes are generally greater than 38 degrees API, while those with less than 22 degrees API are labelled as heavy crude oils.

Specific gravity and API gravity move in opposite directions. API gravity moves in the same direction as energy content per tonne (metric ton), i.e. the higher the API gravity, the higher the energy content per tonne, whereas specific gravity moves in the same direction as energy content per unit volume.

The **JODI Oil Questionnaire** requires oil data to be reported in the unit which your international organisation has adopted, e.g. for OPEC member countries this is in volume units (barrels), for IEA this is in mass (metric tons).

This sometimes requires national statisticians to convert volumetric data into metric tons (or conversely). To the extent possible, information should be obtained from the reporting enterprises on how quantities of crude oil and petroleum products have to be converted from volume to metric tons.

This is particularly important for some of the oil products in gaseous form (e.g. Refinery Gas, Ethane, LPG) which have to be expressed in mass terms.

---

<sup>2</sup> This is approximately the net calorific value of 1 tonne of crude oil.

Below is a table showing typical or average densities, calorific values and derived conversion factors for crude oil and the main oil products.

**Table A2.5 Typical densities, conversion factors and calorific values for crude oil and petroleum products (JODI Oil products are in blue).**

Product	Density kg/m <sup>3</sup>	litres per metric ton	Barrel per metric ton	Gross Calorific Value (GJ/t)	Net Calorific value (GJ/t) <sup>(3)</sup>
Crude oil	853	1172	7.37	47.37	45.00
Ethane	366	2730	17.17	51.90	47.51
Refinery Gas	786	1272	8	52.00	47.60
Propane	508	1969	12.38	50.32	46.33
Butane	585	1709	10.75	49.51	45.72
LPG <sup>(1)</sup>	<b>539</b>	<b>1856</b>	<b>11.67</b>	<b>50.08</b>	<b>46.15</b>
Naphtha	706	1416	8.91	47.73	45.34
Aviation gasoline	707	1414	8.90	47.40	45.03
Motor gasoline <sup>(2)</sup>	741	1350	8.49	47.10	44.75
Jet Kerosene	803	1246	7.84	46.93	44.58
Other Kerosene	810	1235	7.76	46.05	43.75
Gas/Diesel oil	844	1186	7.46	45.66	43.38
Fuel oil low sulphur	925	1081	6.80	43.75	41.56
Fuel oil high sulphur	975	1026	6.45	42.00	39.90
Bunker Fuel oil	975	1026	6.45	42.60	40.47
Fuel Oil (Avg)	<b>944</b>	<b>1059</b>	<b>6.66</b>	<b>42.82</b>	<b>40.68</b>
White Spirit	743	1346	8.46	46.32	44.00
Paraffin Waxes	801	1248	7.85	42.00	39.90
Lubricants	887	1127	7.09	44.00	41.80
Bitumen	1035	966	6.08	42.10	40.00
Petroleum Coke	1150	870	5.47	34.80	33.06
Other Products	786	1273	8.00	42.30	40.19

<sup>(1)</sup> Assumes a mixture of 60% propane and 40% butane by mass.

<sup>(2)</sup> An average for motor gasolines with RON between 91 and 95.

<sup>(3)</sup> For Naphtha and heavier oils the net calorific value is assumed to be 95% of gross.

## 2.2 Daily versus monthly data

One other problem the statistician is faced with sometimes is that the unit used by the oil industry in the country is on a daily basis e.g. barrels per day and data need to be converted to a monthly basis.

The following table offers an example of converting volume (in this case given in barrels per day) to mass (in metric tons) for two different months, e.g. January and February.

**Table A2.6 Example of converting volume to mass**

Imports	Reported data in barrel per day (Volume)	Number of days in Month	Density: Mass/Volume (ton/m <sup>3</sup> Average)	Volume/Mass Barrel per Ton Conversion Factor	Conversion into metric Tons (Mass)
Crude Oil	1020	31	0.853	(1/0.853)/0.159*=7.37	(1020x31)/7.37=4290
Motor Gasoline	546	28	0.741	(1/0.741)/0.159*=8.49	(546x28)/8.49=1801

(\* ) 1 barrel = 159 litres

# List of abbreviations

---

APEC	Asia Pacific Economic Cooperation
API gravity	American Petroleum Institute gravity
ARA	Amsterdam - Rotterdam - Antwerp
b/d	barrels per day
bbbl	barrel
bcm	billion cubic meters
BFOE	Barrel of Fuel Oil Equivalent
BTU/lb	British Thermal Unit per pound
CFBP	Comité Français du Butane et du Propane
cSt	centistoke
EBV	German Oil Storage Association
Eurostat	Statistical Office of the European Communities
Gcal	Giga calories
GWh	Giga Watt hour
IATA	International Air Transport Association
IEA	International Energy Agency
IEF	International Energy Forum
J	Joule
JODI	Joint Organisations Data Initiative
kg/l	kilogrammes per litre
kg/m <sup>3</sup>	kilogrammes per cubic meter
LNG	Liquefied Natural Gas
LPG	Liquefied Petroleum Gas
M-1	Read as M minus one: the month previous to the current month
M-2	Read as M minus two: two months previous to the current month
MOS	Monthly Oil Statistics
Mtoe	Million tonnes of oil equivalent
NATO	North Atlantic Treaty Organisation
NGL	Natural Gas Liquids
NPD	Norwegian Petroleum Directorate
OLADE	Latin-American Energy Organisation
OPEC	Organisation of Petroleum Exporting Countries
RON	Research Octane Number
SBP	Industrial Spirit
SEATO	South East Asia Treaty Organisation
SI Units	Système International d'Unités
SPR	Strategic Petroleum Reserve
TJ	Tera Joule
toe	tonnes of oil equivalent
UFIP	Union Française des Industries Pétrolières
ULCC	Ultra Large Crude Carrier
UNSD	United Nations Statistics Division

Figure A2.1: Oil Industry Flow

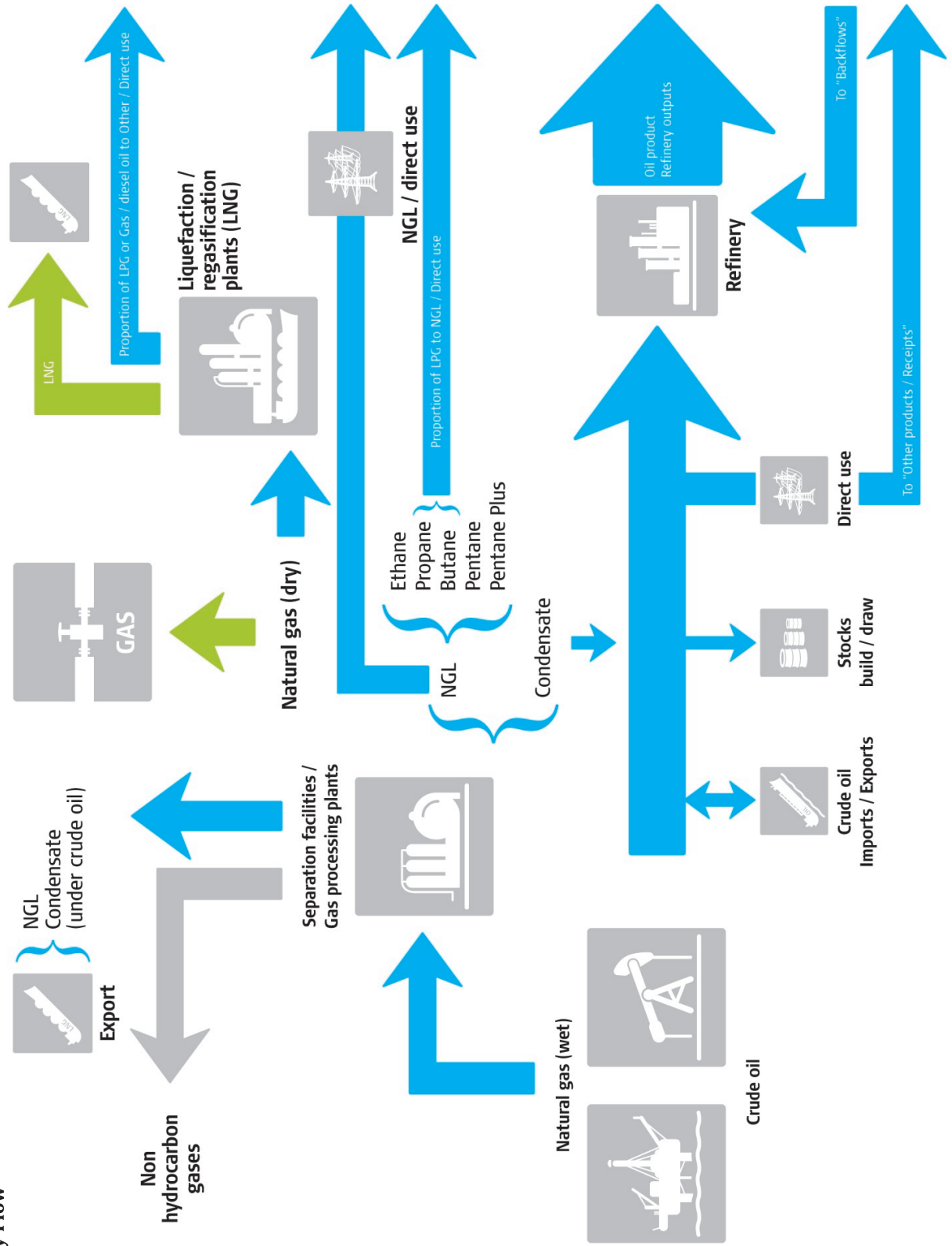

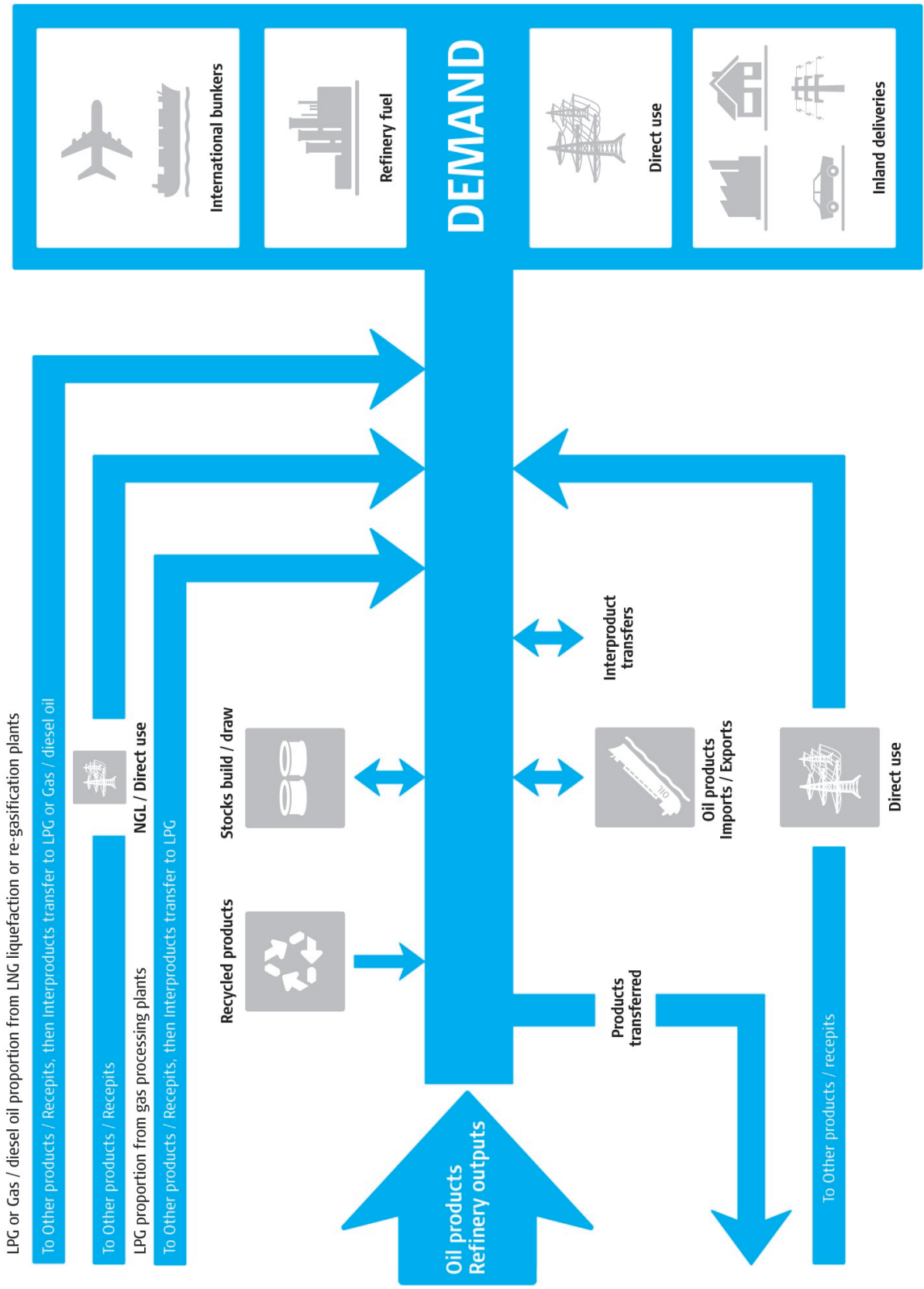





# JodiOil™



## Joint Organisations Data Initiative

Diplomatic Quarter, P.O. Box 94736, Riyadh 11614, Saudi Arabia

[jodi.info@ief.org](mailto:jodi.info@ief.org) [www.jodidata.org](http://www.jodidata.org)